



CRANE SCALE



QINGDAO VENIT IMPORT AND EXPORT CO., LTD

Tel: +86-532-80921252 Fax: +86-532-80921252

Wechat / WhatsApp: +86-18954297651

Sales Manger: Jason E-mail: sales@qdvenit.com

































Website:WWW.QDVENIT.COM

SERVING THE WORLD



PRODUCT CATALOG

产品目录

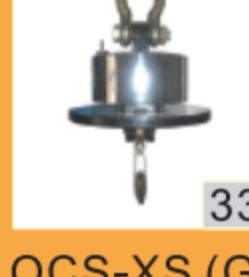
				
OCS (A1) 1t~20t	OCS (A2) 1t~20t	OCS (A3) 1t~20t	OCS (A4) 1t~20t	OCS (B1) 1t~5t
				
OCS (B2) 1t~5t	OCS (B3) 1t~5t	OCS (B4) 1t~5t	OCS (C1) 1t~5t	OCS (C2) 1t~5t
				
OCS (C3) 1t~5t	OCS (C4) 1t~5t	OCS (T) 1t~5t	OCS (X) 1t~5t	OCS (K1) 1t~5t
				
OCS (K2) 10t	OCS (L) 0.03t~0.3t	OCS (L2) 0.03t~0.3t	OCS (L3) 50kg	OCS (S1) 0.1t~1t
				
OCS (S2) 0.1t~1t	OCS (S) 0.1t~1t	OCS (M1) 0.1t~1t	OCS (M2) 0.1t~1t	OCS (Y1) 1t~50t
				
OCS (Y2) 1t~5t	OCS (P) 6, 15, 30kg	OCS (Z) 10t~50t	OCS-XS(E1) 1t~50t	OCS-XS (F2) 5t~20t
				
OCS (G1) 1t~15t	OCS (G2) 10t~30t	OCS-XS (G) 1t~30t		

MODEL : OCS (A1)

产品特点

- 精密模压合金铝机壳
- 工业级镀膜处理
- 美标弓型吊环、环眼吊钩
- 高精度合金钢传感器
- 字高30mm LED 显示
- 不锈钢防水按钮
- 大容量充电电池
- 红外遥控器

基本功能

- 置零去皮
- 示值保持
- 电压显示
- 超载警示
- 自动关机
- 单位切换
- 分度切换

Features

- Precision aluminum alloy case
- High strength paint
- Alloy steel load cell
- 30mm LED display
- Alloy steel shackle and hook
- Rechargeable battery
- Infrared remote control

Functions

- Zero/Tare
- Display hold
- Voltage display
- Overload warning
- Auto power off
- Unit switch
- Resolution switch

Weight and size 秤量和尺寸

Model	Max.cap. kg	d kg	n	A mm	B mm	C mm	L mm	N.W. kg
OCS-1 (A1)	1000	0.5	2000	58	83	30	420	12
OCS-2 (A1)	2000	1	2000	58	83	30	420	13
OCS-3 (A1)	3000	1	3000	73	107	33	480	15
OCS-5 (A1)	5000	2	2500	92	135	45	585	24
OCS-10 (A1)	10000	5	2000	94	147	60	770	43
OCS-15 (A1)	15000	5	3000	128	178	75	860	61
OCS-20 (A1)	20000	10	2000	135	250	75	950	64

➤ Any difference, subject to the actual dimension.

Specification 技术规范

Accuracy class	准确度等级	OIML Ⅲ
Tare range	去皮范围	100%F.S.
Zero range	置零范围	4%F.S.
Safe overload	安全载荷	120%F.S.
Ultimate overload	极限载荷	400%F.S.
Overload warning	超载警示值	100%F.S.+9e
Battery	电池	6V/10Ah
Adaptor	充电器	DC9V/1.5A
Battery life	连续工作时间	>100h
Temperature range	温度范围	-10℃~40℃

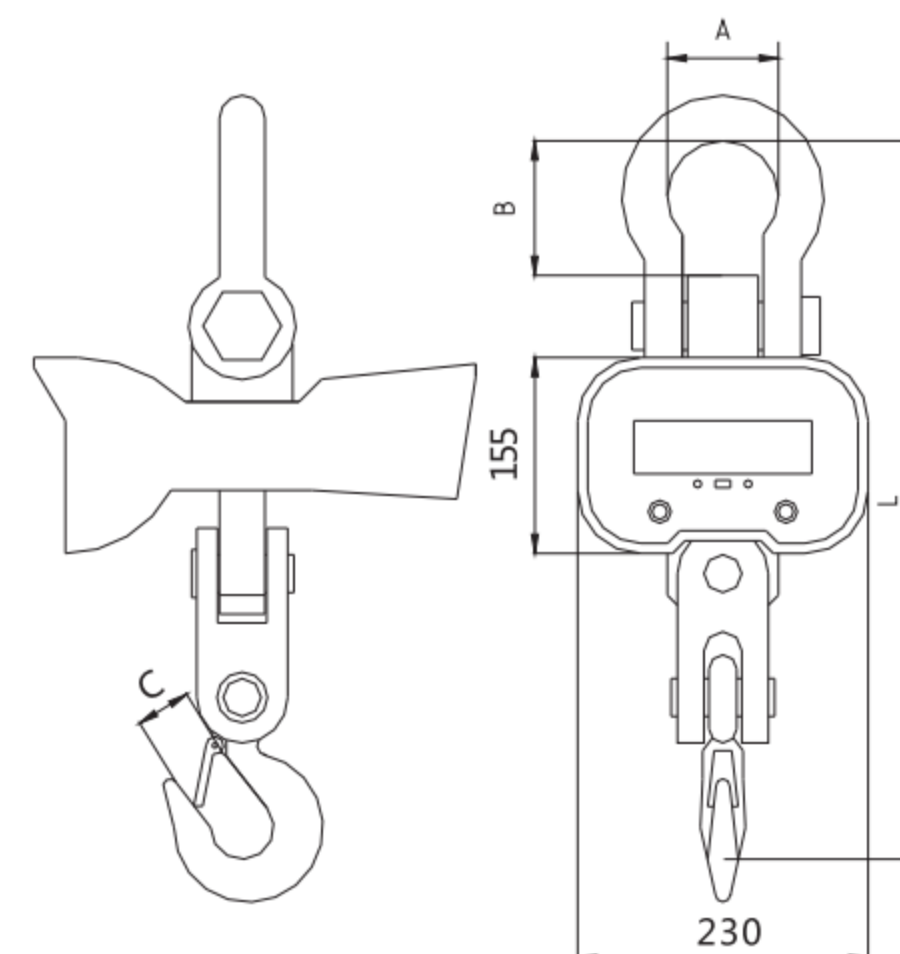

MODEL : OCS (A2)

产品特点

- 精密模压合金铝机壳
- 工业级镀膜处理
- 美标弓型吊环、环眼吊钩
- 高精度合金钢传感器
- 字高34mm LCD 背光显示
- 不锈钢防水按钮
- 大容量充电电池
- 红外遥控器

基本功能

- 置零去皮
- 示值保持
- 电压显示
- 超载警示
- 自动关机
- 单位切换
- 分度切换

Features

- Precision aluminum alloy case
- High strength paint
- Alloy steel load cell
- 34mm LCD display
- Alloy steel shackle and hook
- Rechargeable battery
- Infrared remote control

Functions

- Zero/Tare
- Display hold
- Voltage display
- Overload warning
- Auto power off
- Unit switch
- Resolution switch

Weight and size 秤量和尺寸

Model	Max.cap. kg	d kg	n	A mm	B mm	C mm	L mm	N.W. kg
OCS-1 (A2)	1000	0.5	2000	58	83	30	420	12
OCS-2 (A2)	2000	1	2000	58	83	30	420	13
OCS-3 (A2)	3000	1	3000	73	107	33	480	15
OCS-5 (A2)	5000	2	2500	92	135	45	585	24
OCS-10 (A2)	10000	5	2000	94	147	60	770	43
OCS-15 (A2)	15000	5	3000	128	178	75	860	61
OCS-20 (A2)	20000	10	2000	135	250	75	950	64

➤ Any difference, subject to the actual dimension.

Specification 技术规范

Accuracy class	准确度等级	OIML Ⅲ
Tare range	去皮范围	100%F.S.
Zero range	置零范围	4%F.S.
Safe overload	安全载荷	120%F.S.
Ultimate overload	极限载荷	400%F.S.
Overload warning	超载警示值	100%F.S.+9e
Battery	电池	6V/10Ah
Adaptor	充电器	DC9V/1.5A
Battery life	连续工作时间	>100h
Temperature range	温度范围	-10℃~40℃

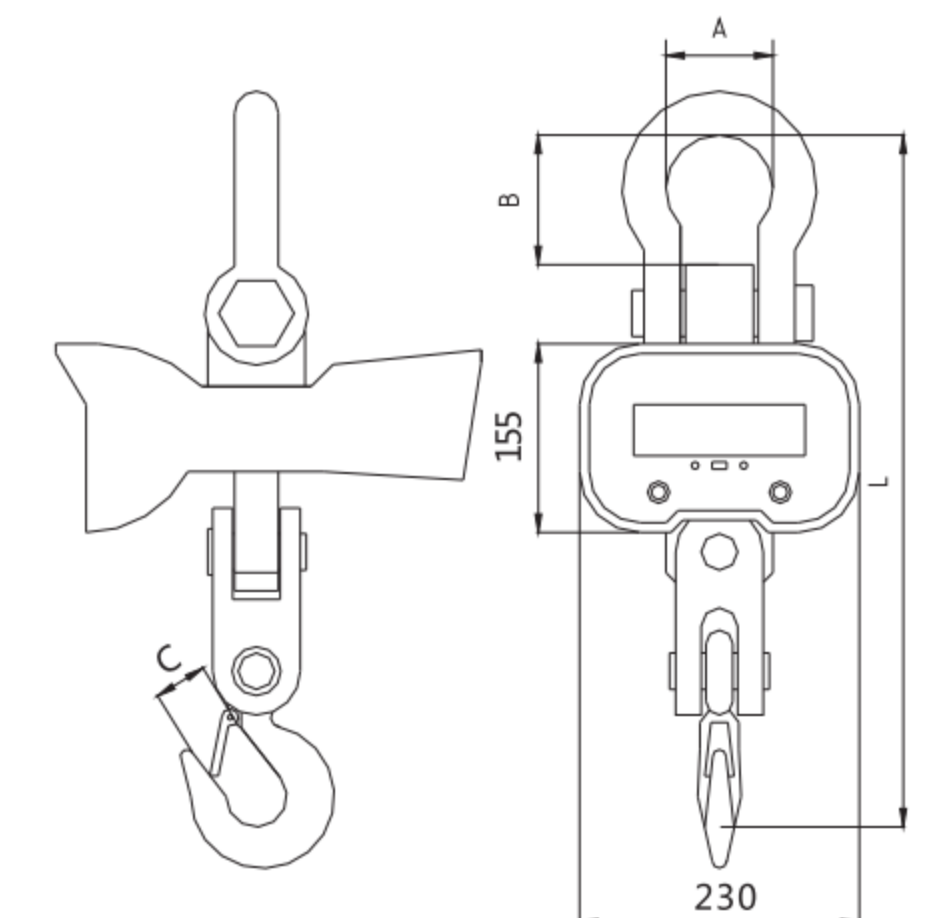

MODEL : OCS (A3)

产品特点

- 精密模压合金铝机壳
- 工业级镀膜处理
- 美标弓型吊环、环眼吊钩
- 高精度合金钢传感器
- 字高38mm LED 显示
- 5位功能按键
- 大容量充电电池
- 红外遥控器

基本功能

- 置零去皮
- 示值保持
- 电压显示
- 超载警示
- 自动关机
- 单位切换
- 分度切换

Features

- Precision aluminum alloy case
- High strength paint
- Alloy steel load cell
- 38mm LED display
- Alloy steel shackle and hook
- Rechargeable battery
- Infrared remote control

Functions

- Zero/Tare
- Display hold
- Voltage display
- Overload warning
- Auto power off
- Unit switch
- Resolution switch

Weight and size 秤量和尺寸

Model	Max.cap. kg	d kg	n	A mm	B mm	C mm	L mm	N.W. kg
OCS-1 (A3)	1000	0.5	2000	58	83	30	420	12
OCS-2 (A3)	2000	1	2000	58	83	30	420	13
OCS-3 (A3)	3000	1	3000	73	107	33	480	15
OCS-5 (A3)	5000	2	2500	92	135	45	585	24
OCS-10 (A3)	10000	5	2000	94	147	60	770	43
OCS-15 (A3)	15000	5	3000	128	178	75	860	61
OCS-20 (A3)	20000	10	2000	135	250	75	950	64

➤ Any difference, subject to the actual dimension.

Specification 技术规范

Accuracy class	准确度等级	OIML Ⅱ
Tare range	去皮范围	100%F.S.
Zero range	置零范围	4%F.S.
Safe overload	安全载荷	120%F.S.
Ultimate overload	极限载荷	400%F.S.
Overload warning	超载警示值	100%F.S.+9e
Battery	电池	6V/10Ah
Adaptor	充电器	DC9V/1.5A
Battery life	连续工作时间	>100h
Temperature range	温度范围	-10℃~40℃

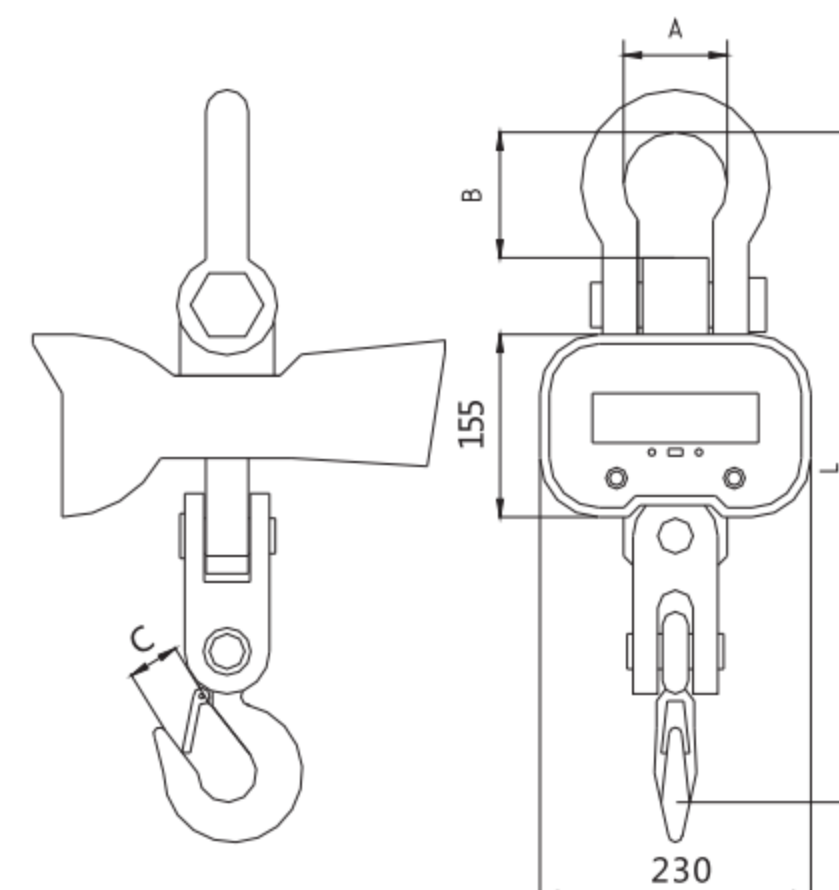

MODEL : OCS (A4)

产品特点

- 精密模压合金铝机壳
- 工业级镀膜处理
- 美标弓型吊环、环眼吊钩
- 高精度合金钢传感器
- 字高34mm LCD 背光显示
- 5位功能按键
- 大容量充电电池
- 红外遥控器

基本功能

- 置零去皮
- 示值保持
- 电压显示
- 超载警示
- 自动关机
- 单位切换
- 分度切换

Features

- Precision aluminum alloy case
- High strength paint
- Alloy steel load cell
- 34mm LCD display
- Alloy steel shackle and hook
- Rechargeable battery
- Infrared remote control

Functions

- Zero/Tare
- Display hold
- Voltage display
- Overload warning
- Auto power off
- Unit switch
- Resolution switch

Weight and size 秤量和尺寸

Model	Max.cap. kg	d kg	n	A mm	B mm	C mm	L mm	N.W. kg
OCS-1 (A4)	1000	0.5	2000	58	83	30	420	12
OCS-2 (A4)	2000	1	2000	58	83	30	420	13
OCS-3 (A4)	3000	1	3000	73	107	33	480	15
OCS-5 (A4)	5000	2	2500	92	135	45	585	24
OCS-10 (A4)	10000	5	2000	94	147	60	770	43
OCS-15 (A4)	15000	5	3000	128	178	75	860	61
OCS-20 (A4)	20000	10	2000	135	250	75	950	64

➤ Any difference, subject to the actual dimension.

Specification 技术规范

Accuracy class	准确度等级	OIML Ⅱ
Tare range	去皮范围	100%F.S.
Zero range	置零范围	4%F.S.
Safe overload	安全载荷	120%F.S.
Ultimate overload	极限载荷	400%F.S.
Overload warning	超载警示值	100%F.S.+9e
Battery	电池	6V/10Ah
Adaptor	充电器	DC9V/1.5A
Battery life	连续工作时间	>100h
Temperature range	温度范围	-10℃~40℃

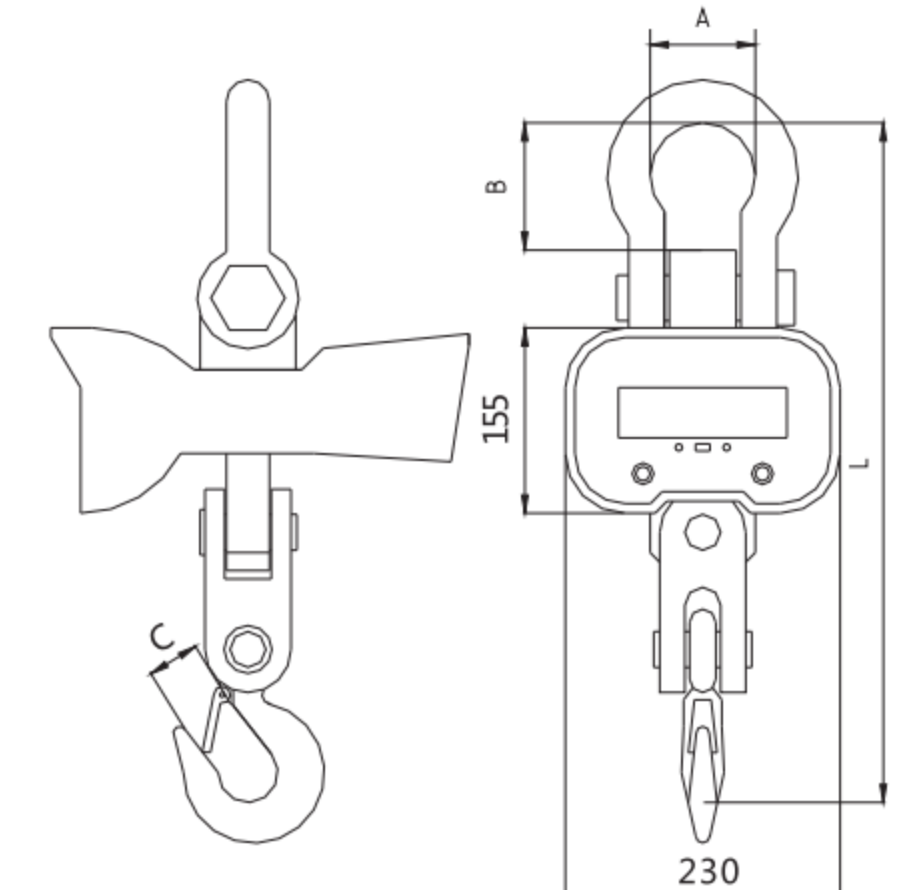

MODEL : OCS (B1)

产品特点

- 精密模压合金铝机壳
- 工业级镀膜处理
- 美标固定式吊环、旋转吊钩
- 高精度合金钢传感器
- 字高30mm LED 显示
- 不锈钢防水按钮
- 大容量充电电池
- 红外遥控器

基本功能

- 置零/去皮
- 示值保持
- 电压显示
- 超载警示
- 自动关机
- 单位切换
- 分度切换

Features

- Precision aluminum alloy case
- High strength paint
- Alloy steel load cell
- 30mm LED display
- Alloy steel shackle and swivel hook
- Rechargeable battery
- Infrared remote control

Functions

- Zero/Tare
- Display hold
- Voltage display
- Overload warning
- Auto power off
- Unit switch
- Resolution switch

Weight and size 秤量和尺寸

Model	Max.cap. kg	d kg	n	A mm	B mm	C mm	L mm	N.W. kg
OCS-1 (B1)	1t	0.5	2000	70	100	35	395	12
OCS-2 (B1)	2t	1	2000	70	100	35	395	12
OCS-3 (B1)	3t	1	3000	70	100	35	395	12
OCS-5 (B1)	5t	2	2500	85	115	40	490	15.5

➤ Any difference, subject to the actual dimension.

Specification 技术规范

Accuracy class	准确度等级	OIML Ⅲ
Tare range	去皮范围	100%F.S.
Zero range	置零范围	4%F.S.
Safe overload	安全载荷	120%F.S.
Ultimate overload	极限载荷	400%F.S.
Overload warning	超载警示值	100%F.S.+9e
Battery	电池	6V/10Ah
Adaptor	充电器	DC9V/1.5A
Battery life	连续工作时间	>100h
Temperature range	温度范围	-10℃~40℃

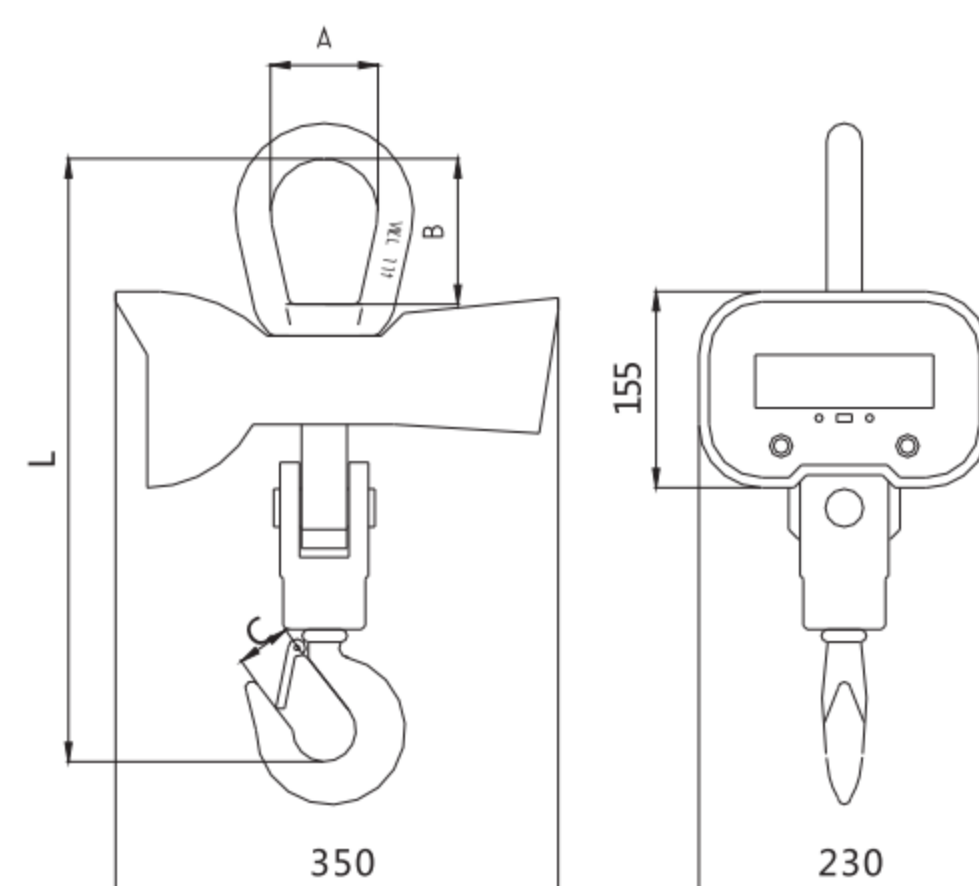

MODEL : OCS (B2)

产品特点

- 精密模压合金铝机壳
- 工业级镀膜处理
- 美标固定式吊环、旋转吊钩
- 高精度合金钢传感器
- 字高34mm LCD 背光显示
- 不锈钢防水按钮
- 大容量充电电池
- 红外遥控器

基本功能

- 置零/去皮
- 示值保持
- 电压显示
- 超载警示
- 自动关机
- 单位切换
- 分度切换

Features

- Precision aluminum alloy case
- High strength paint
- Alloy steel load cell
- 34mm LCD display
- Alloy steel shackle and swivel hook
- Rechargeable battery
- Infrared remote control

Functions

- Zero/Tare
- Display hold
- Voltage display
- Overload warning
- Auto power off
- Unit switch
- Resolution switch

Weight and size 秤量和尺寸

Model	Max.cap. kg	d kg	n	A mm	B mm	C mm	L mm	N.W. kg
OCS-1 (B2)	1t	0.5	2000	70	100	35	395	12
OCS-2 (B2)	2t	1	2000	70	100	35	395	12
OCS-3 (B2)	3t	1	3000	70	100	35	395	12
OCS-5 (B2)	5t	2	2500	85	115	40	490	15.5

➤ Any difference, subject to the actual dimension.

Specification 技术规范

Accuracy class	准确度等级	OIML Ⅲ
Tare range	去皮范围	100%F.S.
Zero range	置零范围	4%F.S.
Safe overload	安全载荷	120%F.S.
Ultimate overload	极限载荷	400%F.S.
Overload warning	超载警示值	100%F.S.+9e
Battery	电池	6V/10Ah
Adaptor	充电器	DC9V/1.5A
Battery life	连续工作时间	>100h
Temperature range	温度范围	-10℃~40℃

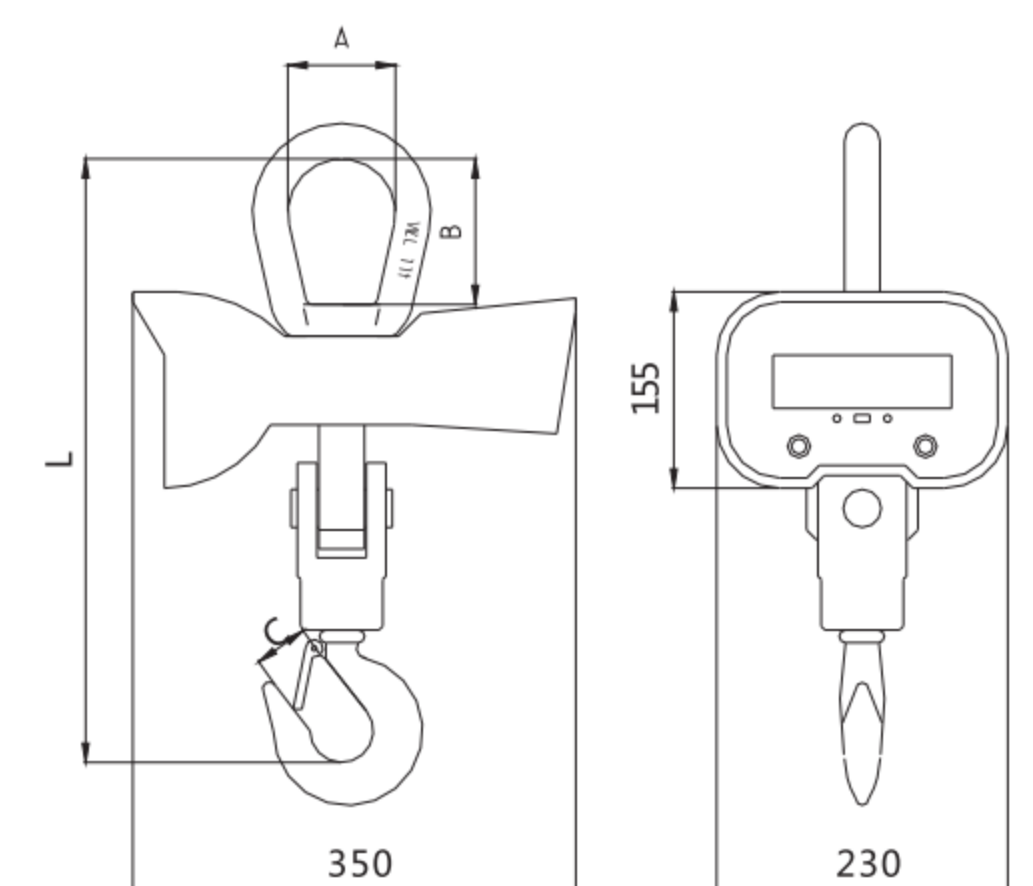

MODEL : OCS (B3)

产品特点

- 精密模压合金铝机壳
- 工业级镀膜处理
- 美标固定式吊环、旋转吊钩
- 高精度合金钢传感器
- 字高38mm LED 显示
- 5位功能按键
- 大容量充电电池
- 红外遥控器

基本功能

- 置零/去皮
- 示值保持
- 电压显示
- 超载警示
- 自动关机
- 单位切换
- 分度切换

Features

- Precision aluminum alloy case
- High strength paint
- Alloy steel load cell
- 38mm LED display
- Alloy steel shackle and swivel hook
- Rechargeable battery
- Infrared remote control

Functions

- Zero/Tare
- Display hold
- Voltage display
- Overload warning
- Auto power off
- Unit switch
- Resolution switch

Weight and size 秤量和尺寸

Model	Max.cap. kg	d kg	n	A mm	B mm	C mm	L mm	N.W. kg
OCS-1 (B3)	1t	0.5	2000	70	100	35	395	12
OCS-2 (B3)	2t	1	2000	70	100	35	395	12
OCS-3 (B3)	3t	1	3000	70	100	35	395	12
OCS-5 (B3)	5t	2	2500	85	115	40	490	15.5

➤ Any difference, subject to the actual dimension.

Specification 技术规范

Accuracy class	准确度等级	OIML Ⅲ
Tare range	去皮范围	100%F.S.
Zero range	置零范围	4%F.S.
Safe overload	安全载荷	120%F.S.
Ultimate overload	极限载荷	400%F.S.
Overload warning	超载警示值	100%F.S.+9e
Battery	电池	6V/10Ah
Adaptor	充电器	DC9V/1.5A
Battery life	连续工作时间	>100h
Temperature range	温度范围	-10℃~40℃

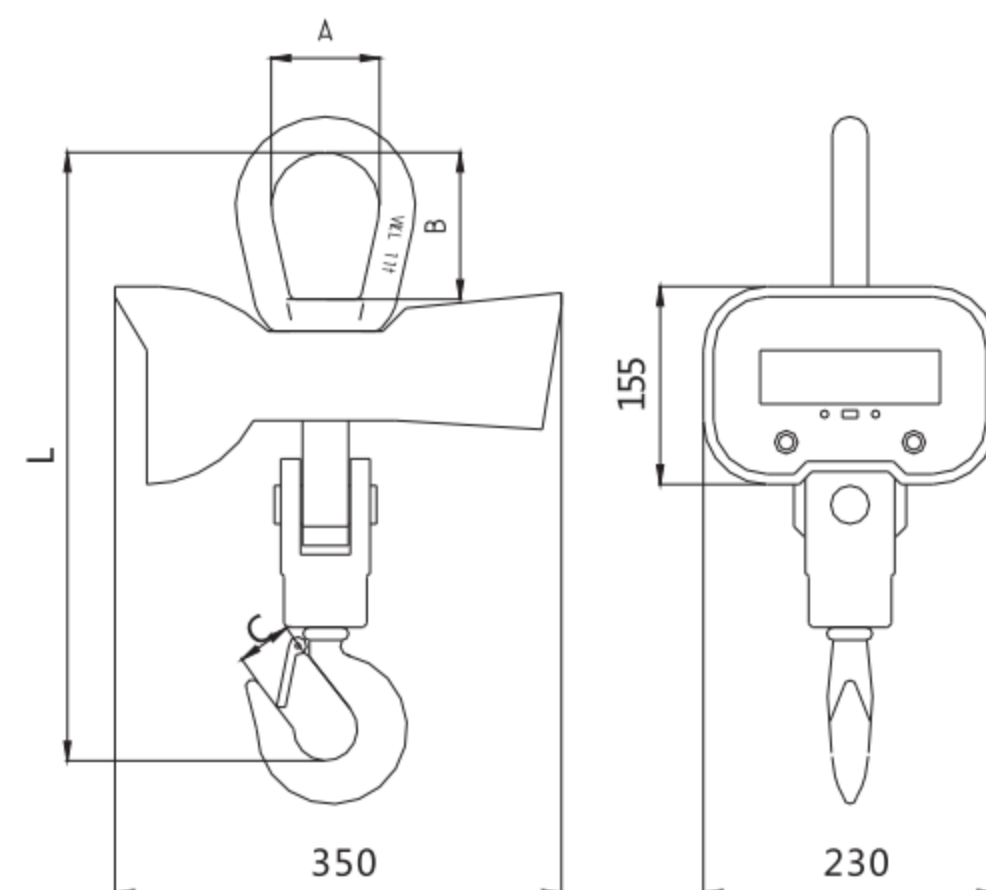

MODEL : OCS (B4)

产品特点

- 精密模压合金铝机壳
- 工业级镀膜处理
- 美标固定式吊环、旋转吊钩
- 高精度合金钢传感器
- 字高34mm LCD 背光显示
- 5位功能按键
- 大容量充电电池
- 红外遥控器

基本功能

- 置零/去皮
- 示值保持
- 电压显示
- 超载警示
- 自动关机
- 单位切换
- 分度切换

Features

- Precision aluminum alloy case
- High strength paint
- Alloy steel load cell
- 34mm LCD display
- Alloy steel shackle and swivel hook
- Rechargeable battery
- Infrared remote control

Functions

- Zero/Tare
- Display hold
- Voltage display
- Overload warning
- Auto power off
- Unit switch
- Resolution switch

Weight and size 秤量和尺寸

Model	Max.cap. kg	d kg	n	A mm	B mm	C mm	L mm	N.W. kg
OCS-1 (B4)	1t	0.5	2000	70	100	35	395	12
OCS-2 (B4)	2t	1	2000	70	100	35	395	12
OCS-3 (B4)	3t	1	3000	70	100	35	395	12
OCS-5 (B4)	5t	2	2500	85	115	40	490	15.5

➤ Any difference, subject to the actual dimension.

Specification 技术规范

Accuracy class	准确度等级	OIML Ⅲ
Tare range	去皮范围	100%F.S.
Zero range	置零范围	4%F.S.
Safe overload	安全载荷	120%F.S.
Ultimate overload	极限载荷	400%F.S.
Overload warning	超载警示值	100%F.S.+9e
Battery	电池	6V/10Ah
Adaptor	充电器	DC9V/1.5A
Battery life	连续工作时间	>100h
Temperature range	温度范围	-10℃~40℃

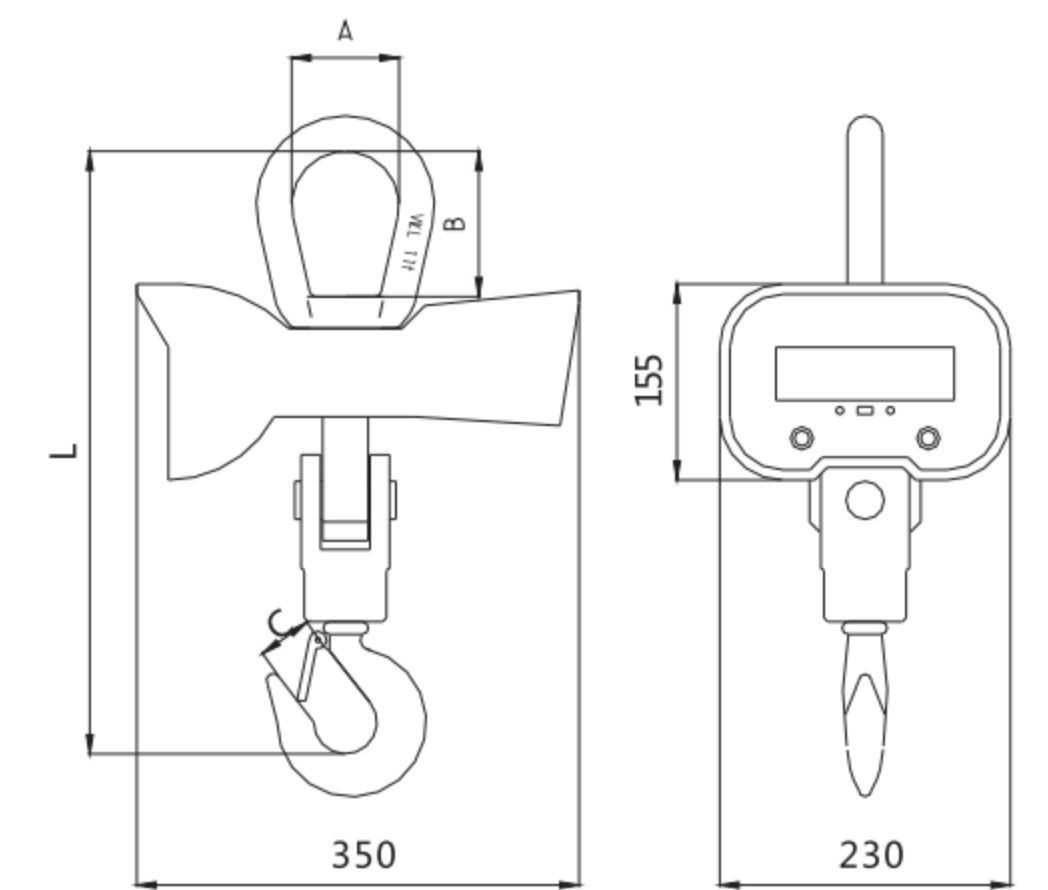

MODEL : OCS (C1)

产品特点

- 精密模压合金铝机壳
- 工业级镀膜处理
- 美标固定式吊环、旋转吊钩
- 高精度合金钢传感器
- 字高30mm LED 显示
- 不锈钢防水按钮
- 更换式充电电池
- 红外遥控器

基本功能

- 置零/去皮
- 示值保持
- 电压显示
- 超载警示
- 自动关机
- 单位切换
- 分度切换

Features

- Precision aluminum alloy case
- High strength paint
- Alloy steel load cell
- 30mm LED display
- Alloy steel shackle and swivel hook
- Rechargeable battery
- Infrared remote control

Functions

- Zero/Tare
- Display hold
- Voltage display
- Overload warning
- Auto power off
- Unit switch
- Resolution switch

Weight and size 秤量和尺寸

Model	Max.cap. kg	d kg	n	A mm	B mm	C mm	L mm	N.W. kg
OCS-1 (C1)	1000	0.5	2000	70	100	35	420	11.5
OCS-2 (C1)	2000	1	2000	70	100	35	420	11.5
OCS-3 (C1)	3000	1	3000	70	100	35	420	11.5
OCS-5 (C1)	5000	2	2500	85	115	40	480	15

➤ Any difference, subject to the actual dimension.

Specification 技术规范

Accuracy class	准确度等级	OIML Ⅲ
Tare range	去皮范围	100%F.S.
Zero range	置零范围	4%F.S.
Safe overload	安全载荷	120%F.S.
Ultimate overload	极限载荷	400%F.S.
Overload warning	超载警示值	100%F.S.+9e
Battery	电池	6V/3.2Ah*2
Adaptor	充电器	DC9V/1.5A
Temperature range	温度范围	-10℃~40℃

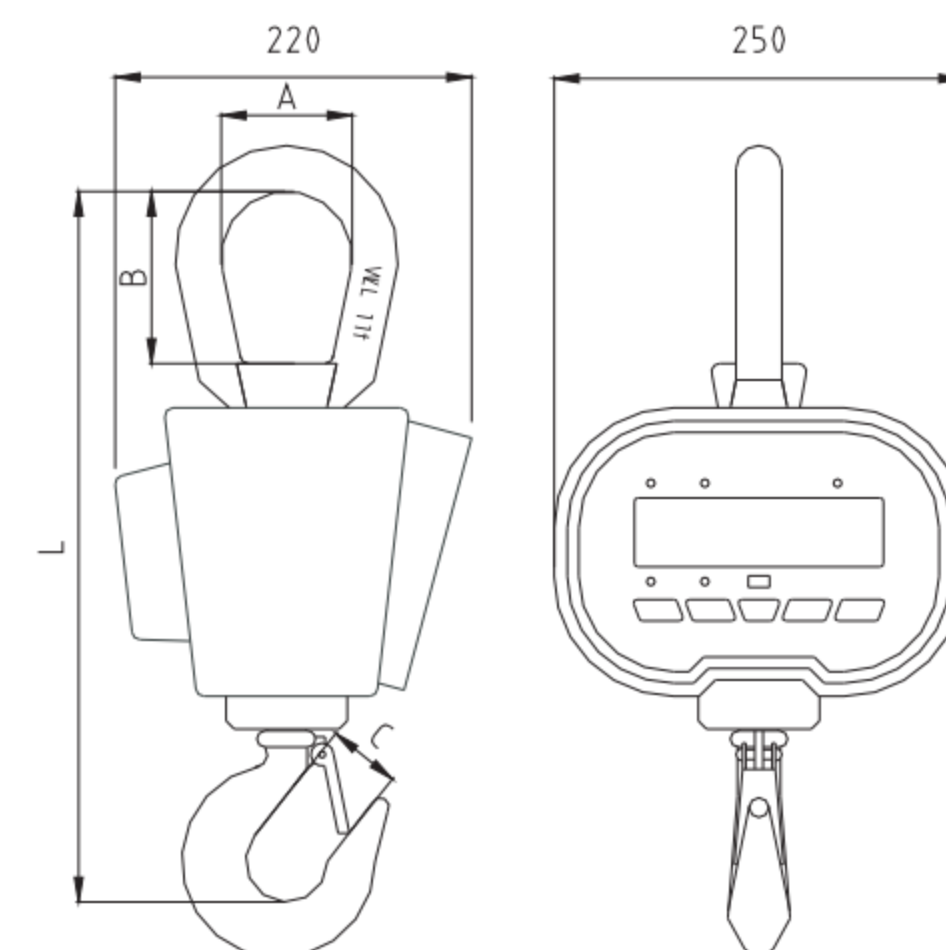

MODEL : OCS (C2)

产品特点

- 精密模压合金铝机壳
- 工业级镀膜处理
- 美标固定式吊环、旋转吊钩
- 高精度合金钢传感器
- 字高34mm LCD 显示
- 不锈钢防水按钮
- 更换式充电电池
- 红外遥控器

基本功能

- 置零/去皮
- 示值保持
- 电压显示
- 超载警示
- 自动关机
- 单位切换
- 分度切换

Features

- Precision aluminum alloy case
- High strength paint
- Alloy steel load cell
- 34mm LCD display
- Alloy steel shackle and swivel hook
- Rechargeable battery
- Infrared remote control

Functions

- Zero/Tare
- Display hold
- Voltage display
- Overload warning
- Auto power off
- Unit switch
- Resolution switch

Weight and size 秤量和尺寸

Model	Max.cap. kg	d kg	n	A mm	B mm	C mm	L mm	N.W. kg
OCS-1 (C2)	1000	0.5	2000	70	100	35	420	11.5
OCS-2 (C2)	2000	1	2000	70	100	35	420	11.5
OCS-3 (C2)	3000	1	3000	70	100	35	420	11.5
OCS-5 (C2)	5000	2	2500	85	115	40	480	15

➤ Any difference, subject to the actual dimension.

Specification 技术规范

Accuracy class	准确度等级	OIML Ⅲ
Tare range	去皮范围	100%F.S.
Zero range	置零范围	4%F.S.
Safe overload	安全载荷	120%F.S.
Ultimate overload	极限载荷	400%F.S.
Overload warning	超载警示值	100%F.S.+9e
Battery	电池	6V/3.2Ah*2
Adaptor	充电器	DC9V/1.5A
Temperature range	温度范围	-10℃~40℃

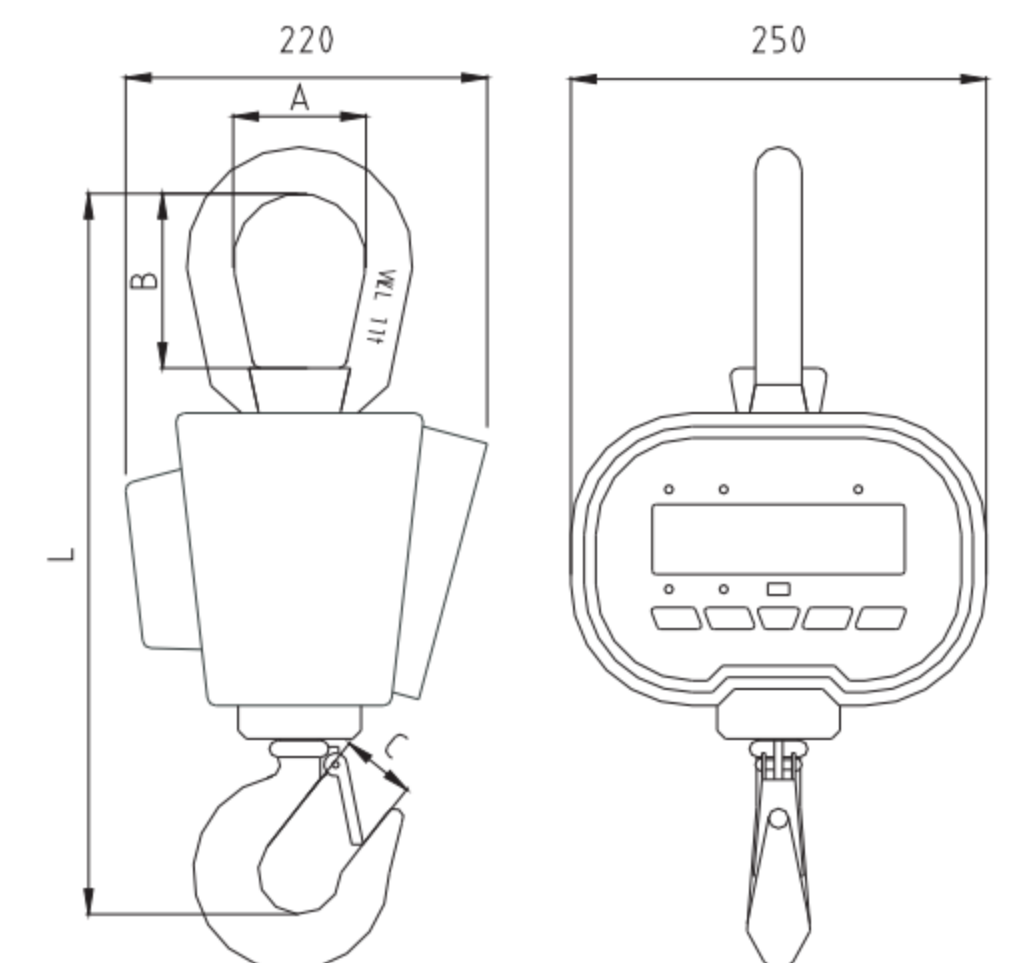

MODEL : OCS (C3)

产品特点

- 精密模压合金铝机壳
- 工业级镀膜处理
- 美标固定式吊环、旋转吊钩
- 高精度合金钢传感器
- 字高38mm LED 显示
- 5位功能按键
- 更换式充电电池
- 红外遥控器

基本功能

- 置零/去皮
- 示值保持
- 电压显示
- 超载警示
- 自动关机
- 单位切换
- 分度切换

Features

- Precision aluminum alloy case
- High strength paint
- Alloy steel load cell
- 38mm LED display
- Alloy steel shackle and swivel hook
- Rechargeable battery
- Infrared remote control

Functions

- Zero/Tare
- Display hold
- Voltage display
- Overload warning
- Auto power off
- Unit switch
- Resolution switch

Weight and size 秤量和尺寸

Model	Max.cap. kg	d kg	n	A mm	B mm	C mm	L mm	N.W. kg
OCS-1 (C3)	1000	0.5	2000	70	100	35	420	11.5
OCS-2 (C3)	2000	1	2000	70	100	35	420	11.5
OCS-3 (C3)	3000	1	3000	70	100	35	420	11.5
OCS-5 (C3)	5000	2	2500	85	115	40	480	15

➤ Any difference, subject to the actual dimension.

Specification 技术规范

Accuracy class	准确度等级	OIML Ⅱ
Tare range	去皮范围	100%F.S.
Zero range	置零范围	4%F.S.
Safe overload	安全载荷	120%F.S.
Ultimate overload	极限载荷	400%F.S.
Overload warning	超载警示值	100%F.S.+9e
Battery	电池	6V/3.2Ah*2
Adaptor	充电器	DC9V/1.5A
Temperature range	温度范围	-10℃~40℃

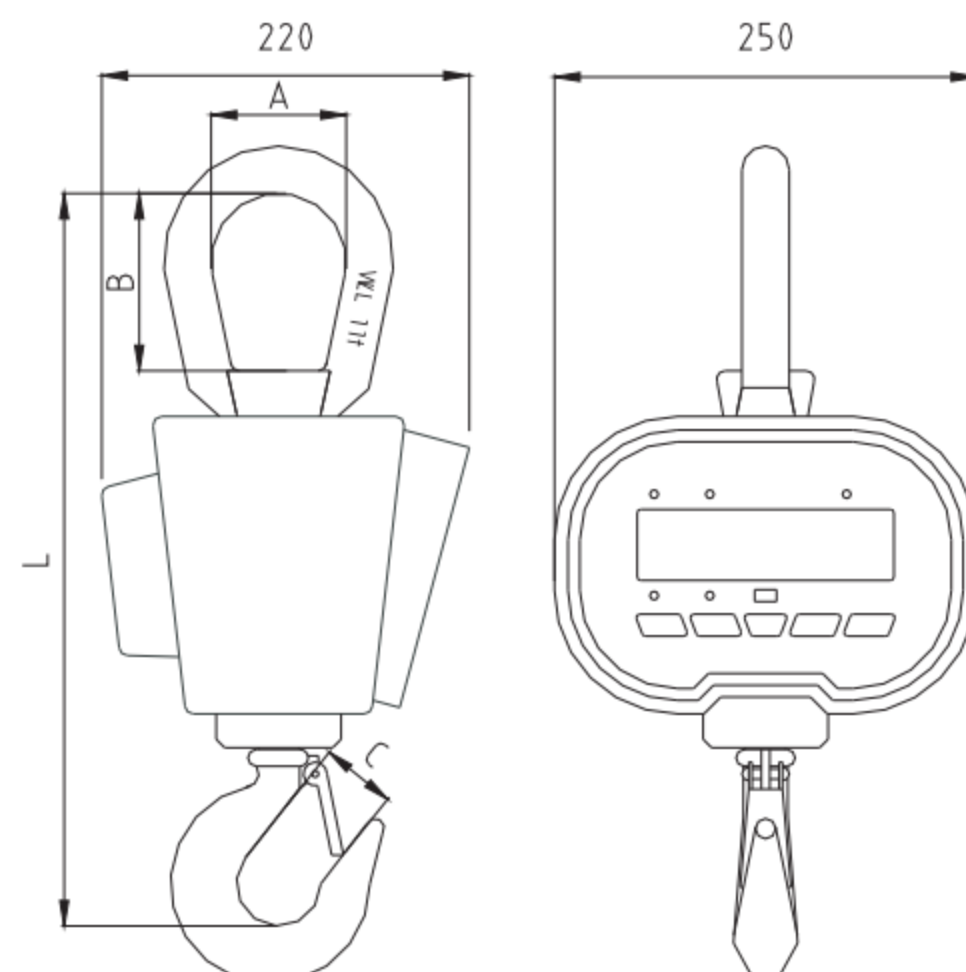

MODEL : OCS (C4)

产品特点

- 精密模压合金铝机壳
- 工业级镀膜处理
- 美标固定式吊环、旋转吊钩
- 高精度合金钢传感器
- 字高34mm LCD 显示
- 5位功能按键
- 更换式充电电池
- 红外遥控器

基本功能

- 置零/去皮
- 示值保持
- 电压显示
- 超载警示
- 自动关机
- 单位切换
- 分度切换

Features

- Precision aluminum alloy case
- High strength paint
- Alloy steel load cell
- 34mm LCD display
- Alloy steel shackle and swivel hook
- Rechargeable battery
- Infrared remote control

Functions

- Zero/Tare
- Display hold
- Voltage display
- Overload warning
- Auto power off
- Unit switch
- Resolution switch

Weight and size 秤量和尺寸

Model	Max.cap. kg	d kg	n	A mm	B mm	C mm	L mm	N.W. kg
OCS-1 (C4)	1000	0.5	2000	70	100	35	420	11.5
OCS-2 (C4)	2000	1	2000	70	100	35	420	11.5
OCS-3 (C4)	3000	1	3000	70	100	35	420	11.5
OCS-5 (C4)	5000	2	2500	85	115	40	480	15

➤ Any difference, subject to the actual dimension.

Specification 技术规范

Accuracy class	准确度等级	OIML Ⅱ
Tare range	去皮范围	100%F.S.
Zero range	置零范围	4%F.S.
Safe overload	安全载荷	120%F.S.
Ultimate overload	极限载荷	400%F.S.
Overload warning	超载警示值	100%F.S.+9e
Battery	电池	6V/3.2Ah*2
Adaptor	充电器	DC9V/1.5A
Temperature range	温度范围	-10℃~40℃

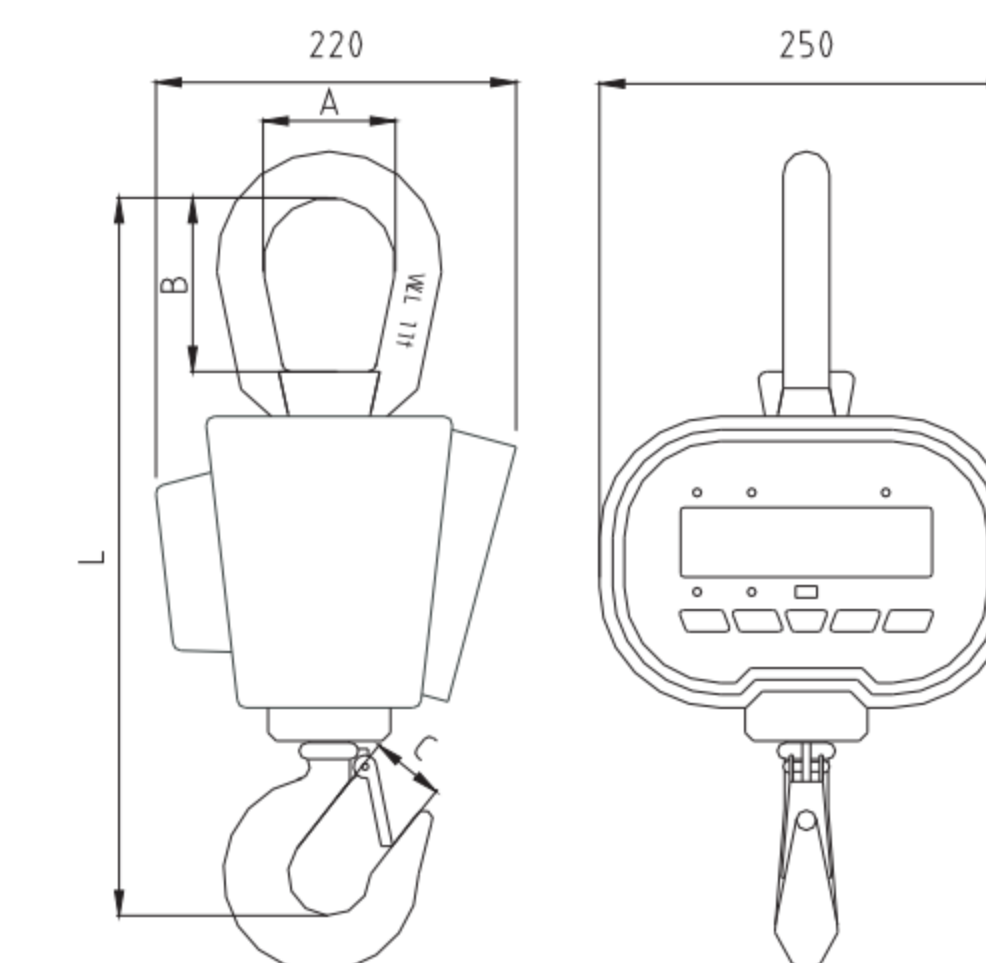

MODEL : OCS (T)

产品特点

- 精密模压合金铝机壳
- 工业级镀膜处理
- 固定式吊环、旋转吊钩
- 高精度合金钢传感器
- 字高35mm LED 显示
- 充电电池
- 红外遥控器

基本功能

- 置零去皮
- 示值保持
- 电压显示
- 超载警示
- 自动关机
- 单位切换
- 分度切换

Features

- Precision aluminum alloy case
- High strength paint
- Alloy steel load cell
- 35mm LED display
- Alloy steel shackle and swivel hook
- Rechargeable battery
- Infrared remote control

Functions

- Zero/Tare
- Display hold
- Voltage display
- Overload warning
- Auto power off
- Unit switch
- Resolution switch

Weight parameter 秤量参数

Model	Max.cap. kg	Min.cap. kg	d kg	n	N.W. kg
OCS-1 (T)	1000	10	0.5	2000	11.6
OCS-2 (T)	2000	20	1	2000	11.6
OCS-3 (T)	3000	20	1	3000	11.6
OCS-5 (T)	5000	40	2	2500	12.8

Specification 技术规范

Accuracy class	准确度等级	OIML Ⅲ
Tare range	去皮范围	100%F.S.
Zero range	置零范围	4%F.S.
Safe overload	安全载荷	120%F.S.
Ultimate overload	极限载荷	400%F.S.
Overload warning	超载警示值	100%F.S.+9e
Battery	电池	6V/4Ah
Adaptor	充电器	DC9V/1.5 A
Battery life	连续工作时间	>60h
Temperature range	温度范围	-10°C~40°C



Size 相关尺寸



MODEL : OCS (X)

产品特点

- 精密模压合金铝机壳
- 工业级镀膜处理
- 固定式吊环、美标环眼吊钩
- 整体式合金钢传感器
- 字高35mm LED 显示
- 充电电池
- 红外遥控器

基本功能

- 置零去皮
- 示值保持
- 电压显示
- 超载警示
- 自动关机
- 单位切换
- 分度切换

Features

- Precision aluminum alloy case
- High strength paint
- Alloy steel load cell
- 35mm LED display
- Alloy steel shackle and hook
- Rechargeable battery
- Infrared remote control

Functions

- Zero/Tare
- Display hold
- Voltage display
- Overload warning
- Auto power off
- Unit switch
- Resolution switch

Weight parameter 秤量参数

Model	Max.cap. kg	Min.cap. kg	d kg	n	N.W. kg
OCS-1 (X)	1000	10	0.5	2000	12.5
OCS-2 (X)	2000	20	1	2000	12.5
OCS-3 (X)	3000	20	1	3000	12.5
OCS-5 (X)	5000	40	2	2500	14

Specification 技术规范

Accuracy class	准确度等级	OIML Ⅲ
Tare range	去皮范围	100%F.S.
Zero range	置零范围	4%F.S.
Safe overload	安全载荷	120%F.S.
Ultimate overload	极限载荷	400%F.S.
Overload warning	超载警示值	100%F.S.+9e
Battery	电池	6V/4Ah
Adaptor	充电器	DC9V/1.5 A
Battery life	连续工作时间	>60h
Temperature range	温度范围	-10°C~40°C



Size 相关尺寸

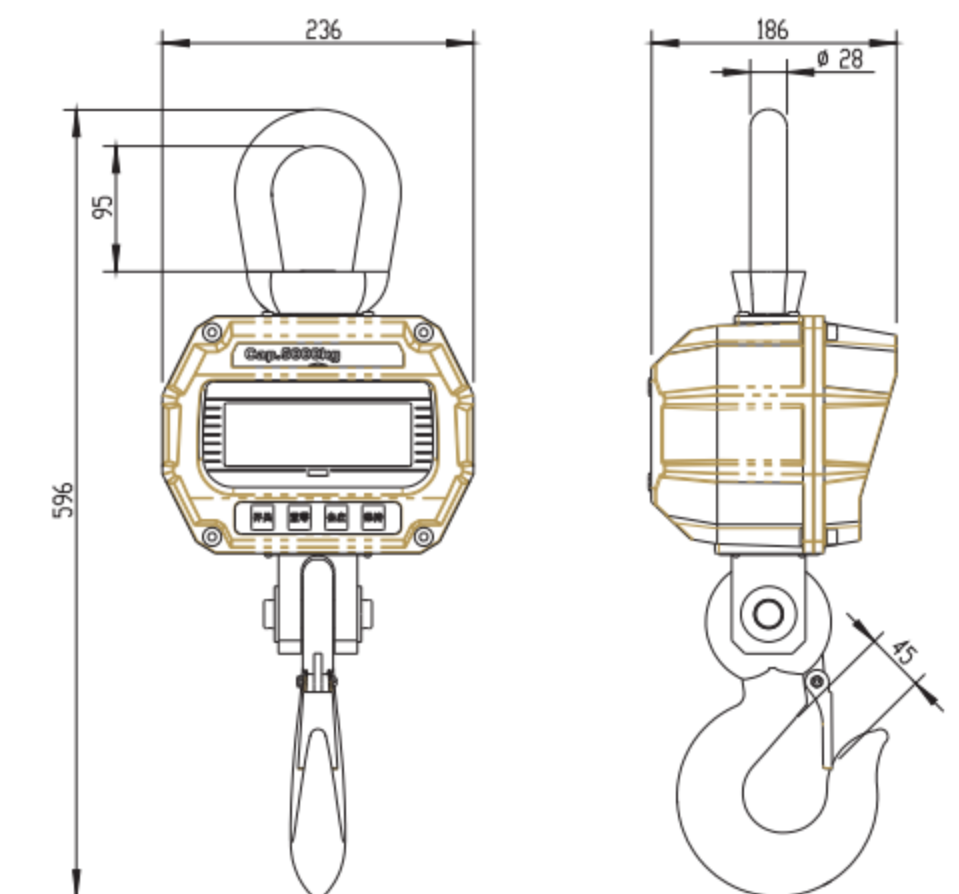

MODEL : OCS (K1)

产品特点

- 精密铸钢机壳
- 工业级镀膜处理
- 合金钢弓型吊环、环眼吊钩
- 整体式合金钢传感器
- 字高35mm LED 显示
- 充电电池
- 红外遥控器

基本功能

- 置零去皮
- 示值保持
- 电压显示
- 超载警示
- 自动关机
- 单位切换
- 分度切换

Features

- Precision alloy steel case
- High strength paint
- Alloy steel load cell
- 35mm LED display
- Alloy steel shackle and hook
- Rechargeable battery
- Infrared remote control

Functions

- Zero/Tare
- Display hold
- Voltage display
- Overload warning
- Auto power off
- Unit switch
- Resolution switch

Weight and size 秤量和尺寸

Model	Max.cap. kg	d kg	n	A mm	B mm	C mm	L mm	N.W. kg
OCS-1 (K1)	1000	0.5	2000	60	100	35	445	14
OCS-2 (K1)	2000	1	2000	60	100	35	445	14
OCS-3 (K1)	3000	1	3000	60	100	35	445	14
OCS-5 (K1)	5000	2	2500	80	115	45	530	19

► Any difference, subject to the actual dimension.

Specification 技术规范

Accuracy class	准确度等级	OIML Ⅲ
Tare range	去皮范围	100%F.S.
Zero range	置零范围	4%F.S.
Safe overload	安全载荷	120%F.S.
Ultimate overload	极限载荷	400%F.S.
Overload warning	超载警示值	100%F.S.+9e
Battery	电池	6V/4Ah
Adaptor	充电器	DC9V/1.5A
Battery life	连续工作时间	>60h
Temperature range	温度范围	-10℃~40℃

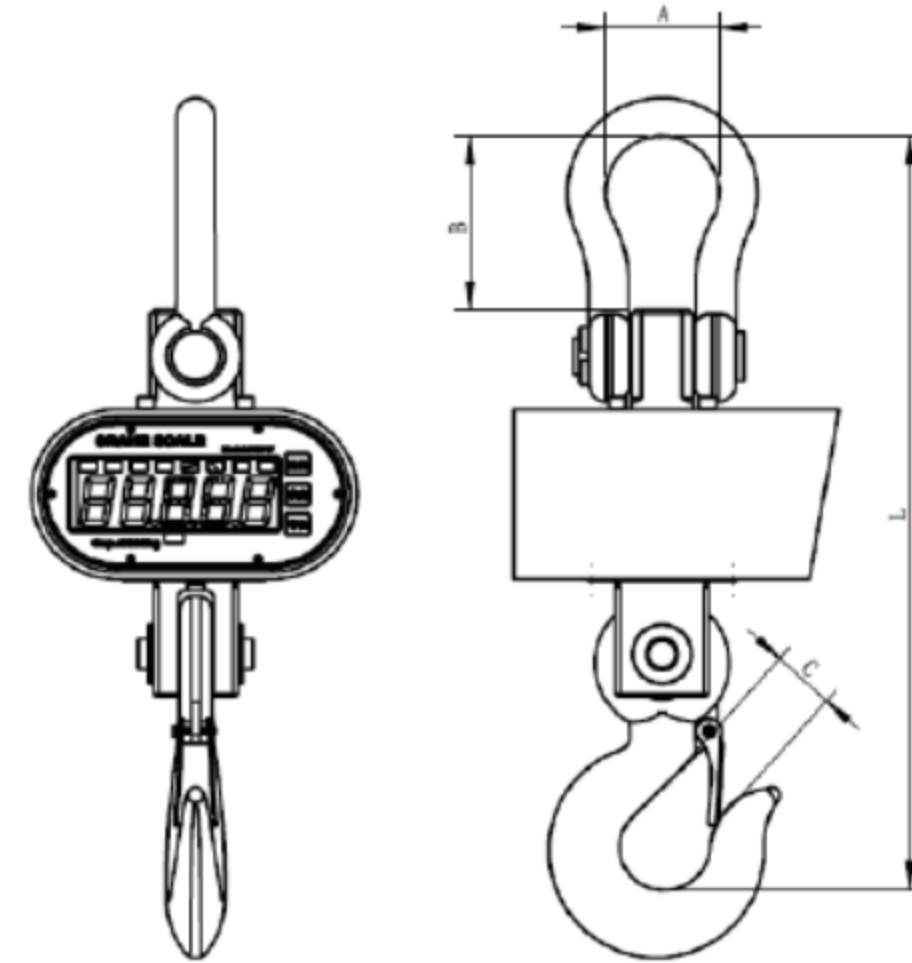

MODEL : OCS (K2)

产品特点

- 精密铸钢机壳
- 工业级镀膜处理
- 美标弓型吊环、环眼吊钩
- 整体式合金钢传感器
- 字高35mm LED 显示
- 充电电池
- 红外遥控器

基本功能

- 置零去皮
- 示值保持
- 电压显示
- 超载警示
- 自动关机
- 单位切换
- 分度切换

Features

- Precision alloy steel case
- High strength paint
- Alloy steel load cell
- 35mm LED display
- Alloy steel shackle and hook
- Rechargeable battery
- Infrared remote control

Functions

- Zero/Tare
- Display hold
- Voltage display
- Overload warning
- Auto power off
- Unit switch
- Resolution switch

Weight parameter 秤量参数

Model	Max.cap. kg	Min.cap. kg	d kg	n
OCS-10 (K2)	10000	100	5	2000

Specification 技术规范

Accuracy class	准确度等级	OIML Ⅲ
Tare range	去皮范围	100%F.S.
Zero range	置零范围	4%F.S.
Safe overload	安全载荷	120%F.S.
Ultimate overload	极限载荷	400%F.S.
Overload warning	超载警示值	100%F.S.+9e
Battery	电池	6V/4Ah
Adaptor	充电器	DC9V/1.5A
Battery life	连续工作时间	>60h
Temperature range	温度范围	-10℃~40℃
N.W.	净重	31kg

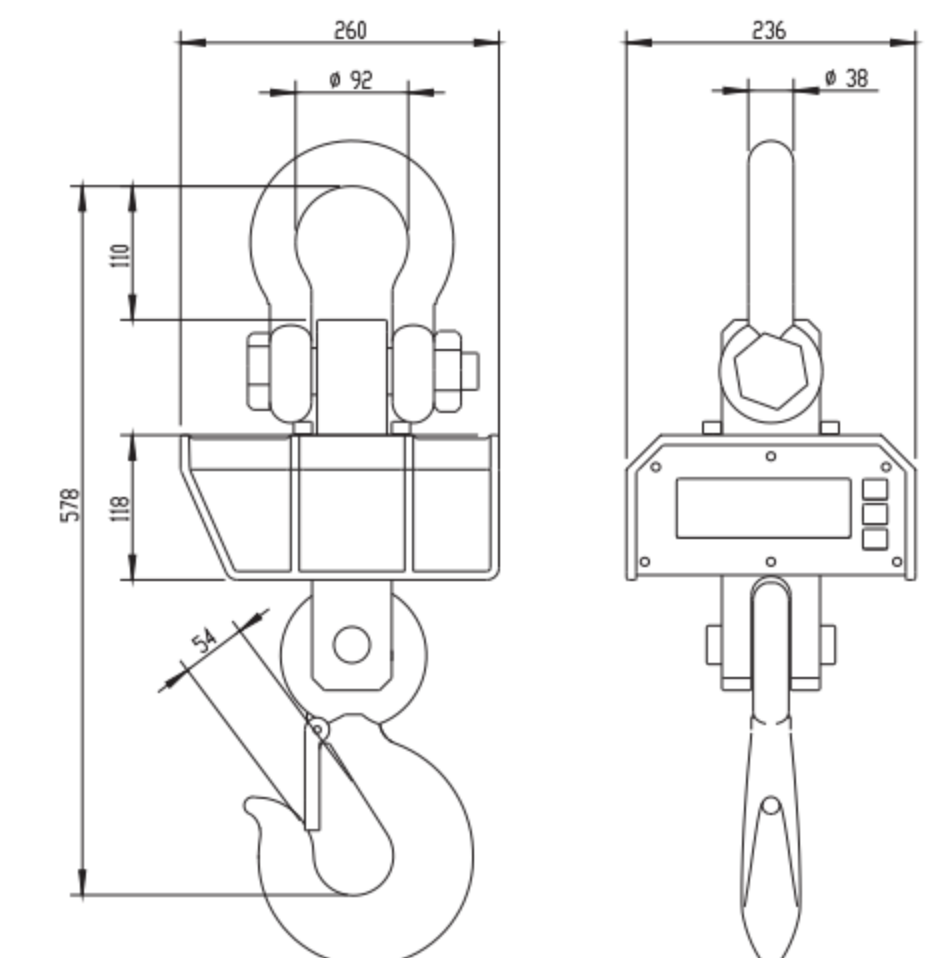

Size 相关尺寸

MODEL : OCS (L)

产品特点

- 精密模压合金铝机壳
- 工业级镀膜处理
- 不锈钢吊环、挂钩
- 整体式高精度传感器
- 字高18mm LCD 背光显示
- 5#电池供电
- 多种机壳颜色选择

基本功能

- 置零/去皮
- 示值保持
- 电压显示
- 超载警示
- 自动关机
- 单位切换
- 分度切换

Features

- Precision aluminum alloy case
- High strength paint
- 18mm LCD display
- Stainless steel shackle and hook
- AA*3 battery
- Optional colors

Functions

- Zero/Tare
- Display hold
- Voltage display
- Overload warning
- Auto power off
- Unit switch
- Resolution switch

Optional colours 可选颜色



Weight parameter 秤量参数

Model	Max.cap.		Min.cap.		Degree		Number
	kg	lb	kg	lb	kg	lb	
OCS-003 (L)	30	60	0.2	0.4	0.01	0.02	3000
OCS-006 (L)	60	120	0.4	0.8	0.02	0.05	3000
OCS-015 (L)	150	300	1	2	0.05	0.1	3000
OCS-03 (L)	300	600	2	4	0.1	0.2	3000

➤ Any difference, subject to the actual dimension.

Specification 技术规范

Accuracy class	准确度等级	OIML Ⅲ
Tare range	去皮范围	100%F.S.
Zero range	置零范围	4%F.S.
Safe overload	安全载荷	120%F.S.
Ultimate overload	极限载荷	300%F.S.
Overload warning	超载警示值	100%F.S.+9e
Battery	电池	AA *3
Temperature range	温度范围	-10°C~40°C
N.W.	净重	600g



Size 相关尺寸

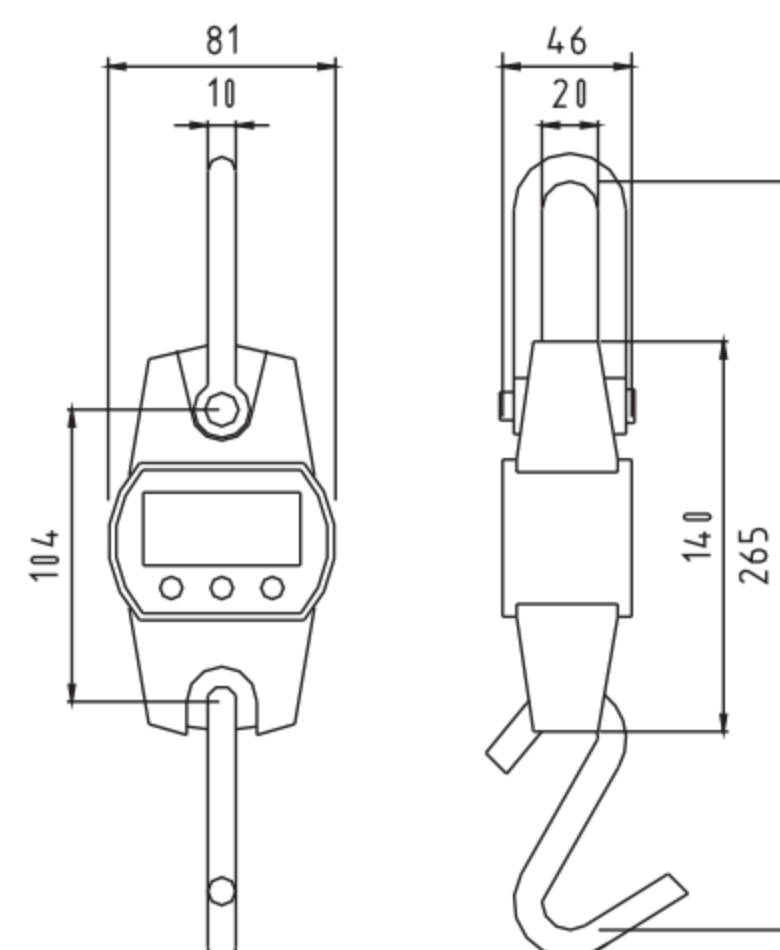

MODEL : OCS (L2)

产品特点

- 精密模压合金铝机壳
- 工业级镀膜处理
- 不锈钢吊环、挂钩
- 整体式高精度传感器
- 字高24mm LCD 背光显示
- 5#电池供电
- 多种机壳颜色选择

基本功能

- 置零/去皮
- 示值保持
- 电压显示
- 超载警示
- 自动关机
- 单位切换
- 分度切换

Features

- Precision aluminum alloy case
- High strength paint
- Integrated load structure
- 24mm LCD display
- Stainless steel shackle and hook
- AA*3 battery
- Optional colors

Functions

- Zero/Tare
- Display hold
- Voltage display
- Overload warning
- Auto power off
- Unit switch
- Resolution switch

Optional colours 可选颜色



Weight parameter 秤量参数

Model	Max.cap.		Min.cap.		Degree		Number
	kg	lb	kg	lb	kg	lb	
OCS-003 (L2)	30	60	0.2	0.4	0.01	0.02	3000
OCS-006 (L2)	60	120	0.4	0.8	0.02	0.05	3000
OCS-015 (L2)	150	300	1	2	0.05	0.1	3000
OCS-03 (L2)	300	600	2	4	0.1	0.2	3000

➤ Any difference, subject to the actual dimension.

Specification 技术规范

Accuracy class	准确度等级	OIML Ⅲ
Tare range	去皮范围	100%F.S.
Zero range	置零范围	4%F.S.
Safe overload	安全载荷	120%F.S.
Ultimate overload	极限载荷	300%F.S.
Overload warning	超载警示值	100%F.S.+9e
Battery	电池	AA *3
Temperature range	温度范围	-10°C~40°C
N.W.	净重	650g



Size 相关尺寸

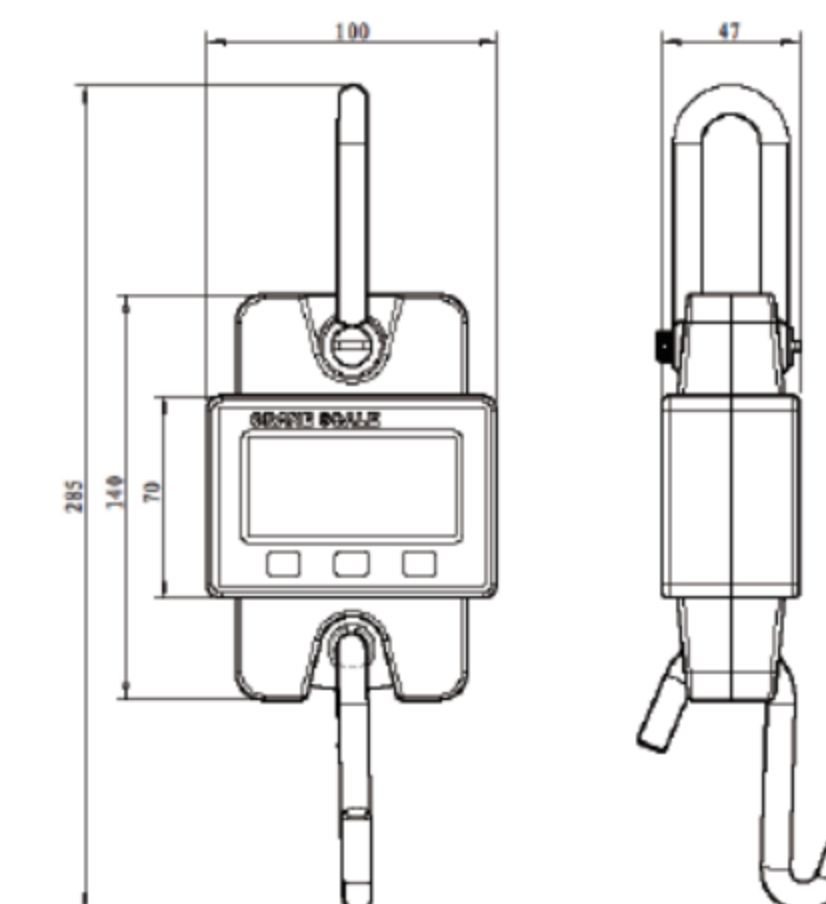

MODEL : OCS (L3)

产品特点

- 精密模压合金铝机壳
- 工业级镀膜处理
- 高强度合金钢挂钩
- 高精度传感器
- 字高20mm LCD 背光显示
- 7#电池供电
- 多种机壳颜色选择

基本功能

- 置零/去皮
- 示值保持
- 自动关机
- 单位切换

Features

- Precision aluminum alloy case
- High strength paint
- High strength alloy steel hook
- 20mm LCD display
- AAA *2 battery
- Optional colors

Functions

- Zero/Tare
- Display hold
- Auto power off
- Unit switch

Optional colours 可选颜色



Specification 技术规范

Model	型号	OCS(L3)
Capacity	量程	50kg
Division	分度值	5g
Power	电源	2xAAA batteries
Weighing units	单位	kg, 1b, oz
Weight	重量	G.W.:0.28kg N.W.:0.22kg



Size 相关尺寸

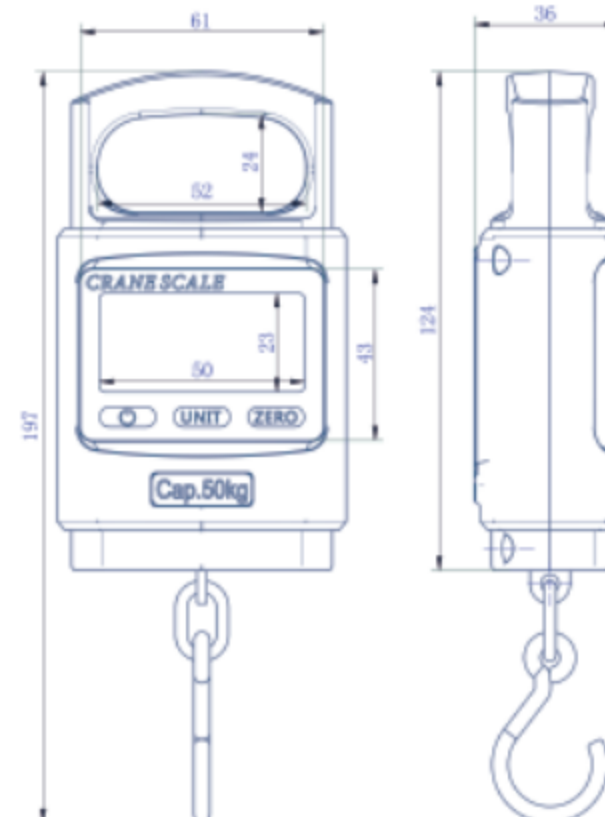

MODEL : OCS (S1)

产品特点

- 精密模压合金铝机壳
- 工业级镀膜处理
- 不锈钢吊环、合金钢吊钩
- 整体式载荷结构
- 字高25mm LED 显示
- 5#电池供电
- 多种机壳颜色选择

基本功能

- 置零/去皮
- 示值保持
- 电压显示
- 超载警示
- 自动关机
- 单位切换
- 分度切换

Features

- Precision aluminum alloy case
- High strength paint
- Integrated load structure
- 25mm LED display
- Stainless steel shackle and alloy steel hook
- AA *4 battery
- Optional colors

Functions

- Zero/Tare
- Display hold
- Voltage display
- Overload warning
- Auto power off
- Unit switch
- Resolution switch

Optional colours 可选颜色



Weight parameter 秤量参数

Model	Max.cap.		Min.cap.		Degree		Number
	kg	lb	kg	lb	kg	lb	
OCS-01 (S1)	100	200	1	2	0.05	1	2000
OCS-02 (S1)	200	400	2	4	0.1	0.2	2000
OCS-03 (S1)	300	600	2	4	0.1	0.2	3000
OCS-05 (S1)	500	1000	4	10	0.2	0.5	2500
OCS-1 (S1)	1000	2000	10	20	0.5	1	2000

➤ Any difference, subject to the actual dimension.

Specification 技术规范

Accuracy class	准确度等级	OIML Ⅲ
Tare range	去皮范围	100%F.S.
Zero range	置零范围	4%F.S.
Safe overload	安全载荷	120%F.S.
Ultimate overload	极限载荷	400%F.S.
Overload warning	超载警示值	100%F.S.+9e
Battery	电池	AA *4
Temperature range	温度范围	-10°C~40°C
N.W.	净重	1.4kg



Size 相关尺寸

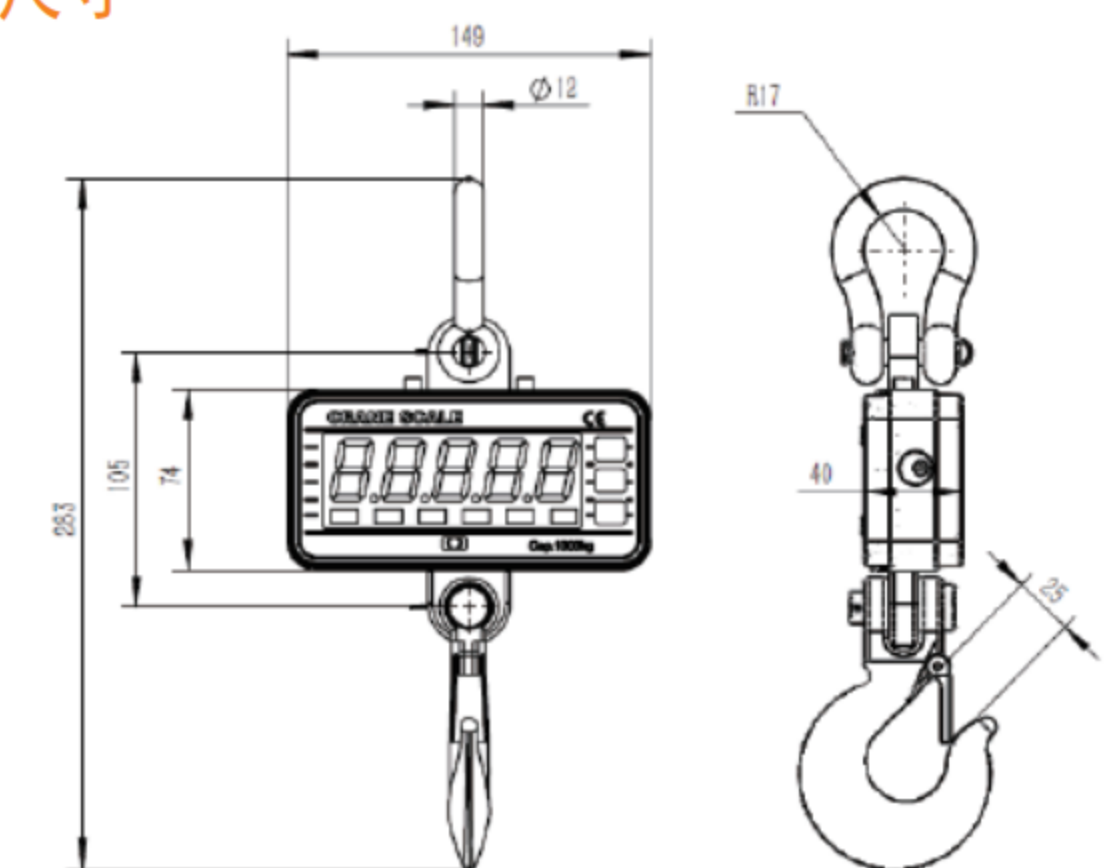

MODEL : OCS (S2)

产品特点

- 精密模压合金铝机壳
- 工业级镀膜处理
- 不锈钢吊环、合金钢吊钩
- 整体式合金钢传感器
- 字高43mm LCD 背光显示
- 5#电池供电
- 多种机壳颜色选择

基本功能

- 置零/去皮
- 自动关机
- 示值保持
- 单位切换
- 电压显示
- 分度切换
- 超载警示

Features

- Precision aluminum alloy case
- High strength paint
- Integrated load structure
- 43 mm LCD display
- Stainless steel shackle and alloy steel hook
- AA*4 battery
- Optional colors

Functions

- Zero/Tare
- Auto power off
- Display hold
- Unit switch
- Voltage display
- Resolution switch
- Overload warning

Optional colours 可选颜色



Weight parameter 称量参数

Model	Max.cap.		Min.cap.		Degree		Number
	kg	lb	kg	lb	kg	lb	
OCS-01 (S2)	100	200	1	2	0.05	0.1	2000
OCS-02 (S2)	200	400	2	4	0.1	0.2	2000
OCS-03 (S2)	300	600	2	4	0.1	0.2	3000
OCS-05 (S2)	500	1000	4	10	0.2	0.5	2500
OCS-1 (S2)	1000	2000	10	20	0.5	1	2000

➤ Any difference, subject to the actual dimension.

Specification 技术规范

Accuracy class	准确度等级	OIML Ⅲ
Tare range	去皮范围	100%F.S.
Zero range	置零范围	4%F.S.
Safe overload	安全载荷	120%F.S.
Ultimate overload	极限载荷	400%F.S.
Overload warning	超载警示值	100%F.S.+9e
Battery	电池	AA*4
Temperature range	温度范围	-10°C~40°C
N.W.	净重	1.4kg



Size 相关尺寸

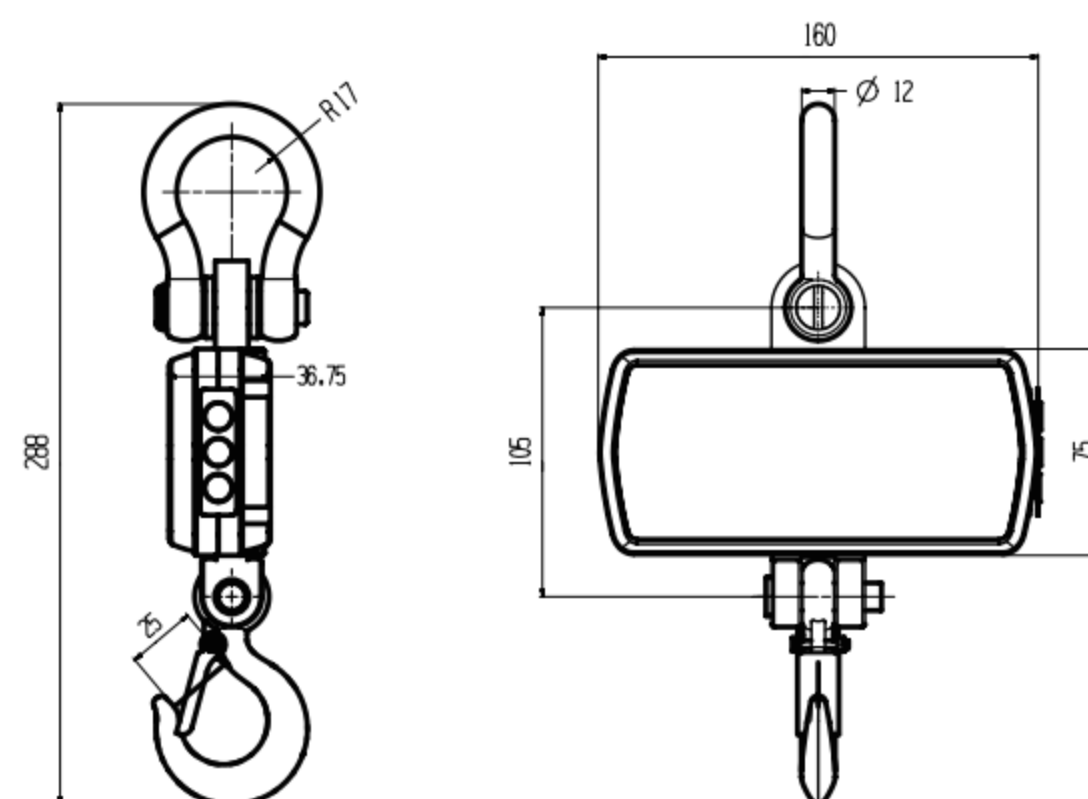

MODEL : OCS (S)

产品特点

- 精密模压合金铝机壳
- 工业级镀膜处理
- 不锈钢吊环、合金钢吊钩
- 整体式合金钢传感器
- 字高22mm LCD 背光显示
- 5#电池供电
- 多种机壳颜色选择

基本功能

- 置零/去皮
- 自动关机
- 示值保持
- 单位切换
- 电压显示
- 分度切换
- 超载警示

Features

- Precision aluminum alloy case
- High strength paint
- Integrated load structure
- 22mm LCD display
- Stainless steel shackle and alloy steel hook
- AA*3 battery
- Optional colors

Functions

- Zero/Tare
- Auto power off
- Display hold
- Unit switch
- Voltage display
- Resolution switch
- Overload warning

Optional colours 可选颜色



Weight parameter 称量参数

Model	Max.cap.		Min.cap.		Degree		Number
	kg	lb	kg	lb	kg	lb	
OCS-01 (S)	100	200	1	2	0.05	0.1	2000
OCS-02 (S)	200	400	2	4	0.1	0.2	2000
OCS-03 (S)	300	600	2	4	0.1	0.2	3000
OCS-05 (S)	500	1000	4	10	0.2	0.5	2500
OCS-1 (S)	1000	2000	10	20	0.5	1	2000

➤ Any difference, subject to the actual dimension.

Specification 技术规范

Accuracy class	准确度等级	OIML Ⅲ
Tare range	去皮范围	100%F.S.
Zero range	置零范围	4%F.S.
Safe overload	安全载荷	120%F.S.
Ultimate overload	极限载荷	400%F.S.
Overload warning	超载警示值	100%F.S.+9e
Battery	电池	AA*3
Temperature range	温度范围	-10°C~40°C
N.W.	净重	1.4kg



Size 相关尺寸

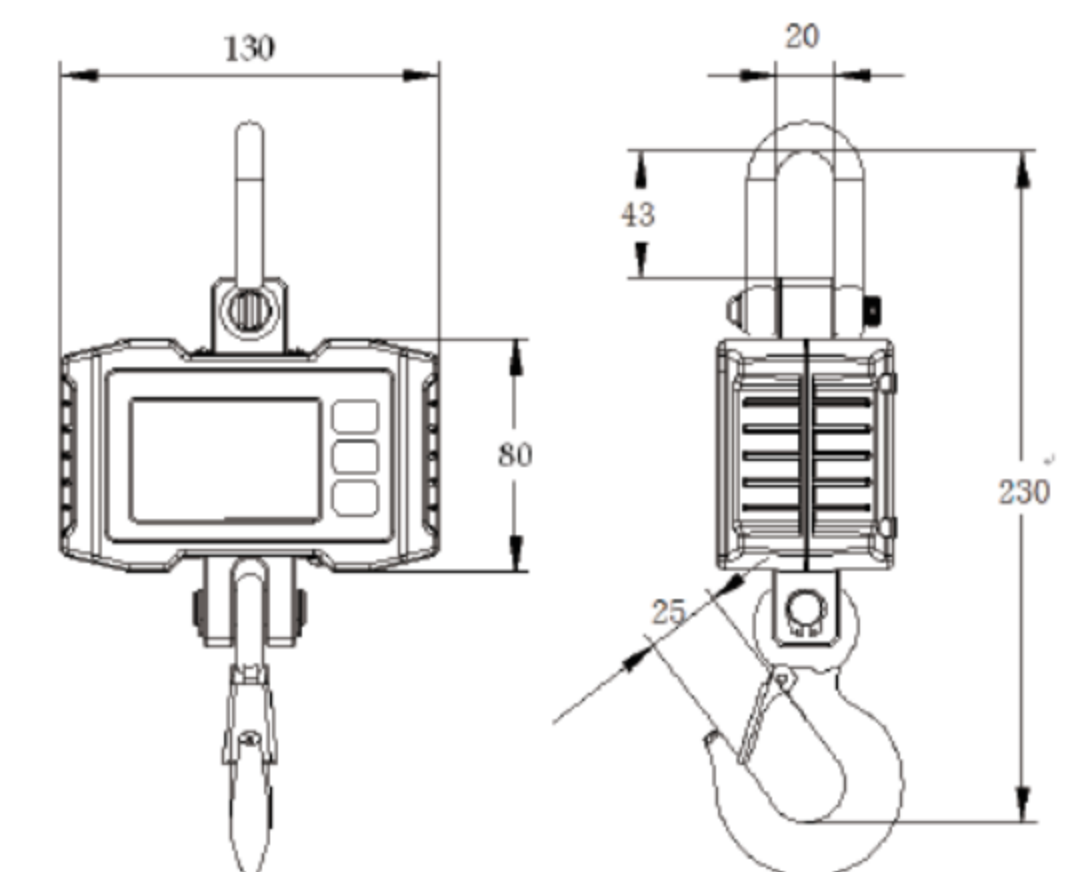

MODEL : OCS (M1)

产品特点

- 精密模压合金铝机壳
- 工业级镀膜处理
- 不锈钢吊环、合金钢吊钩
- 高精度合金钢传感器
- 字高30mm LED 显示
- 大容量充电电池
- 红外遥控器

基本功能

- 置零去皮
- 示值保持
- 电压显示
- 超载警示
- 自动关机
- 单位切换
- 分度切换

Features

- Aluminum die-casting case
- High strength paint
- Alloy steel load cell
- 30mm LED display
- Stainless steel shackle and alloy steel hook
- Rechargeable battery
- Infrared remote control

Functions

- Zero/Tare
- Display hold
- Voltage display
- Overload warning
- Auto power off
- Unit switch
- Resolution switch

Optional colours 可选颜色



Weight and size 秤量和尺寸

Model	Max.cap. kg	d kg	n	A mm	B mm	C mm	L mm	N.W. kg
OCS-01 (M1)	100	0.05	2000	20	80	25	350	5
OCS-02 (M1)	200	0.1	2000	20	80	25	350	5
OCS-03 (M1)	300	0.1	3000	20	80	25	350	5
OCS-05 (M1)	500	0.2	2500	25	85	35	370	5.5
OCS-1 (M1)	1000	0.5	2000	25	85	35	370	5.5

➤ Any difference, subject to the actual dimension.

Specification 技术规范

Accuracy class	准确度等级	OIML Ⅲ
Tare range	去皮范围	100%F.S.
Zero range	置零范围	4%F.S.
Safe overload	安全载荷	120%F.S.
Ultimate overload	极限载荷	400%F.S.
Overload warning	超载警示值	100%F.S.+9e
Battery	电池	6V/5Ah
Adaptor	充电器	DC9V/1.5A
Battery life	连续工作时间	>80h
Temperature range	温度范围	-10℃~40℃

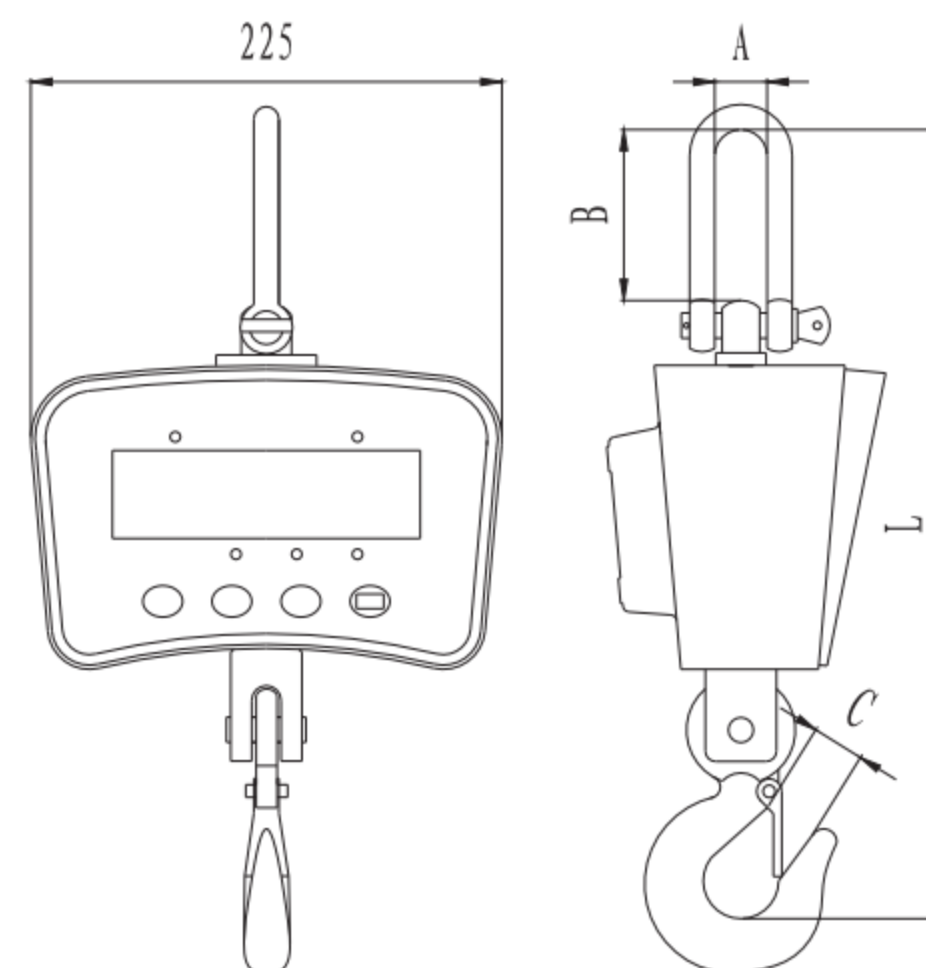

MODEL : OCS (M2)

产品特点

- 精密模压合金铝机壳
- 工业级镀膜处理
- 不锈钢吊环、合金钢吊钩
- 高精度合金钢传感器
- 字高34mm LCD 显示
- 大容量充电电池
- 红外遥控器

基本功能

- 置零去皮
- 示值保持
- 电压显示
- 超载警示
- 自动关机
- 单位切换
- 分度切换

Features

- Aluminum die-casting case
- High strength paint
- Alloy steel load cell
- 34mm LCD display
- Stainless steel shackle and alloy steel hook
- Rechargeable battery
- Infrared remote control

Functions

- Zero/Tare
- Display hold
- Voltage display
- Overload warning
- Auto power off
- Unit switch
- Resolution switch

Optional colours 可选颜色



Weight and size 秤量和尺寸

Model	Max.cap. kg	d kg	n	A mm	B mm	C mm	L mm	N.W. kg
OCS-01 (M2)	100	0.05	2000	20	80	25	350	5
OCS-02 (M2)	200	0.1	2000	20	80	25	350	5
OCS-03 (M2)	300	0.1	3000	20	80	25	350	5
OCS-05 (M2)	500	0.2	2500	25	85	35	370	5.5
OCS-1 (M2)	1000	0.5	2000	25	85	35	370	5.5

➤ Any difference, subject to the actual dimension.

Specification 技术规范

Accuracy class	准确度等级	OIML Ⅲ
Tare range	去皮范围	100%F.S.
Zero range	置零范围	4%F.S.
Safe overload	安全载荷	120%F.S.
Ultimate overload	极限载荷	400%F.S.
Overload warning	超载警示值	100%F.S.+9e
Battery	电池	6V/5Ah
Adaptor	充电器	DC9V/1.5A
Battery life	连续工作时间	>80h
Temperature range	温度范围	-10℃~40℃

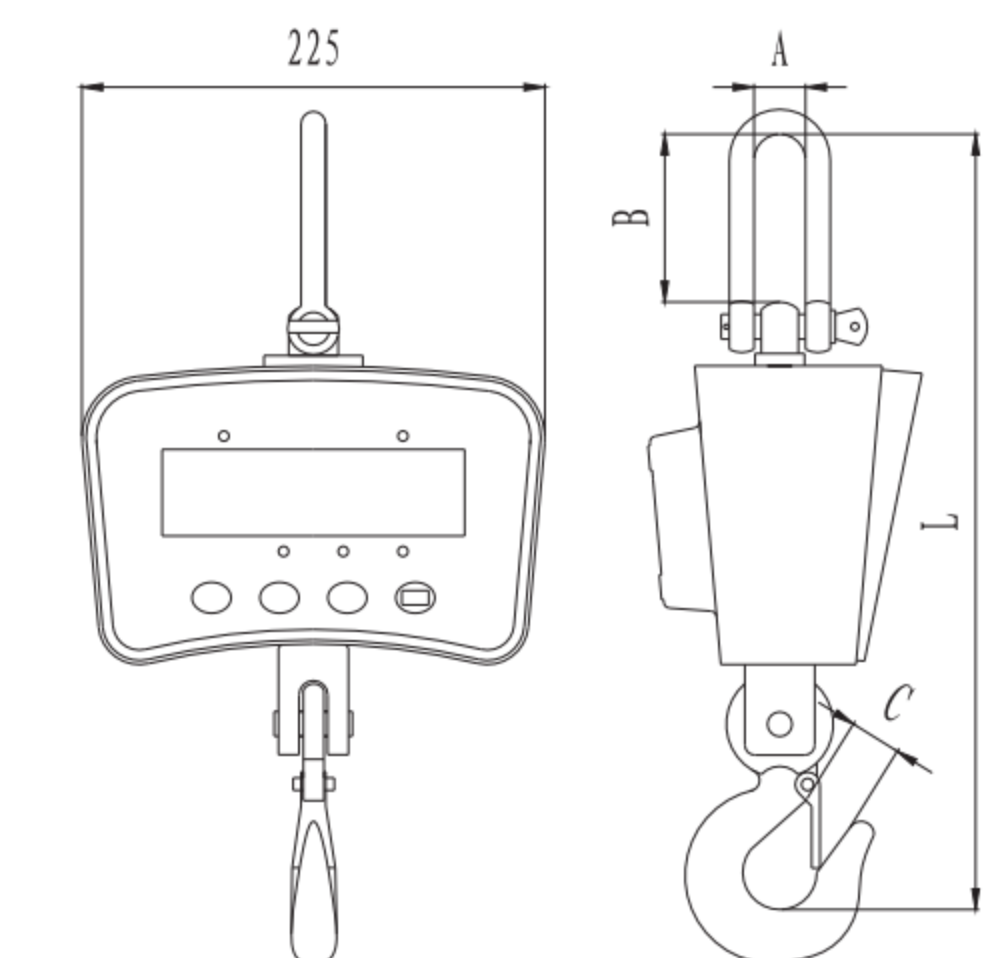

MODEL : OCS (Y1)

产品特点

- 整体式合金钢载荷结构
- 字高22mm LCD 显示
- 防水型面板按键
- 5#电池供电
- 可选配手持显示器

基本功能

- 置零去皮
- 示值保持
- 电压显示
- 超载警示
- 自动关机
- 单位切换
- 分度切换

Features

- Integrated load structure
- 22mm LCD display
- Waterproof panel
- AA*3 battery
- handheld indicator optional

Functions

- Zero/Tare
- Display hold
- Voltage display
- Overload warning
- Auto power off
- Unit switch
- Resolution switch

Weight and size 秤量和尺寸

Model	Max.cap. kg	d kg	n	A mm	B mm	C mm	L mm	Φ mm	Material
OCS-3 (Y1)	3000	1	3000	90	30	165	230	25	Aluminum alloy
OCS-5 (Y1)	5000	2	2500	90	30	165	230	32	Alloy steel
OCS-10 (Y1)	10000	5	2000	90	48	195	280	32	Alloy steel
OCS-20 (Y1)	20000	10	2000	126	60	230	350	50	Alloy steel
OCS-30 (Y1)	30000	10	3000	126	62	232	366	60	Alloy steel
OCS-50 (Y1)	50000	20	2500	180	70	320	500	72	Alloy steel

➤ Any difference, subject to the actual dimension.

Specification 技术规范

Accuracy class	准确度等级	OIML Ⅲ
Tare range	去皮范围	100%F.S.
Zero range	置零范围	4%F.S.
Safe overload	安全载荷	120%F.S.
Ultimate overload	极限载荷	400%F.S.
Overload warning	超载警示值	100%F.S.+9e
Battery	电池	AA *3
Temperature range	温度范围	-10°C~40°C

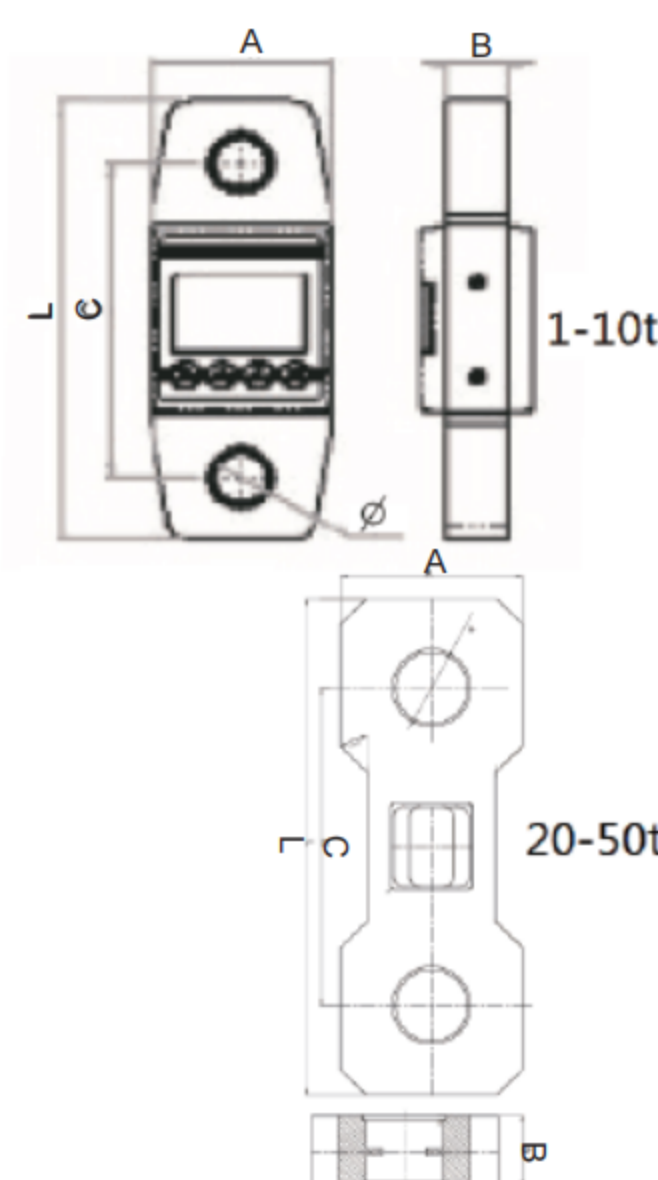

MODEL : OCS (Y2)

产品特点

- 高强度合金钢传感器
- 字高22mm LCD 显示
- 防水型面板按键
- 5#电池供电
- 可选配手持显示器

基本功能

- 置零去皮
- 示值保持
- 电压显示
- 超载警示
- 自动关机
- 单位切换
- 分度切换

Features

- High strength alloy steel loadcell
- 22mm LCD display
- Waterproof panel
- AA*3 battery
- hand held indicator optional

Functions

- Zero/Tare
- Display hold
- Voltage display
- Overload warning
- Auto power off
- Unit switch
- Resolution switch

Weight parameter 秤量参数

Model	Max.cap. kg	Min.cap. kg	d kg	Number n
OCS-1 (Y2)	1000	10	0.5	2000
OCS-2 (Y2)	2000	20	1	2000
OCS-3 (Y2)	3000	20	1	3000
OCS-5 (Y2)	5000	40	2	2500

Specification 技术规范

Accuracy class	准确度等级	OIML Ⅲ
Tare range	去皮范围	100%F.S.
Zero range	置零范围	4%F.S.
Safe overload	安全载荷	120%F.S.
Ultimate overload	极限载荷	400%F.S.
Overload warning	超载警示值	100%F.S.+9e
Battery	电池	AA *3
Temperature range	温度范围	-10°C~40°C

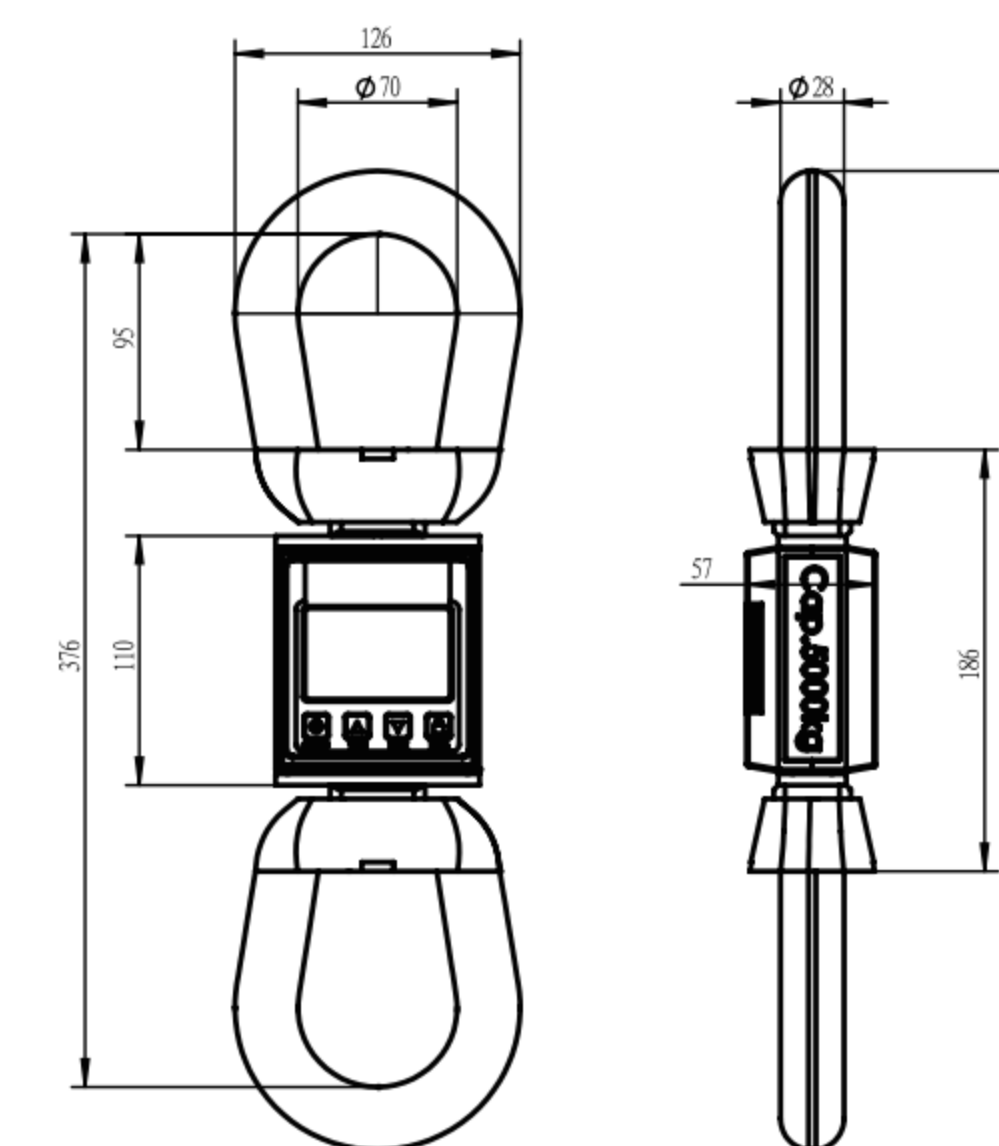

产品特点

- 工程塑料机壳
- 超薄设计
- 高精度合金铝传感器
- 字高22mm LCD 背光双面显示
- 无线遥控
- 充电电池
- 多种机壳颜色选择

基本功能

- 置零/去皮
- 单位切换
- 示值保持
- 称量/单价/总价
- 电压显示

Features

- ABS case
- Double-side LCD display
- Ultrathin design
- Aluminum alloy load cell
- Wireless remote control
- Optional colors
- Rechargeable battery

Functions

- Zero/Tare
- Unit switch
- Display hold
- 3-point calibration
- Voltage display

Weight parameter 秤量参数

Model	Max.cap. kg	Min.cap. kg	Degree g	Number n
OCS-006 (P1)	6	0.04	2	3000
OCS-015 (P1)	15	0.1	5	3000
OCS-030 (P1)	30	0.2	10	3000

Specification 技术规范

Accuracy class	准确度等级	OIML Ⅲ
Tare range	去皮范围	100%F.S.
Zero range	置零范围	4%F.S.
Overload warning	超载警示值	100%F.S.+9e
Battery	电池	6V/3.2Ah
Adaptor	充电器	DC9V/500ma
Battery life	连续工作时间	>60h
N.W.	净重	3.1kg



Size 相关尺寸

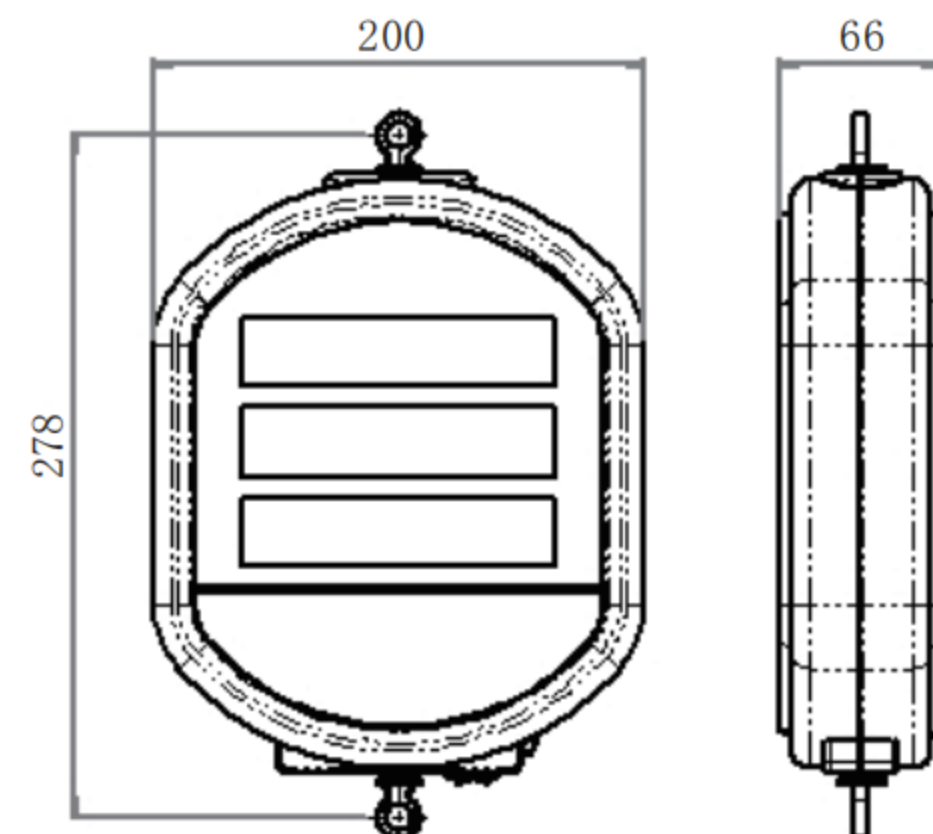

产品特点

- 增强结构全钢机壳
- 工业级镀膜处理
- 合金钢弓型吊环、环眼吊钩
- 整体式合金钢传感器
- 字高56mm LED 显示
- 更换式大容量充电电池
- 红外遥控器

基本功能

- 置零/去皮
- 自动关机
- 示值保持
- 单位切换
- 电压显示
- 分度切换
- 超载警示

Features

- Alloy steel case
- High strength paint
- Alloy steel load cell
- 56mm LED display
- Alloy steel shackle and hook
- Infrared remote control

Functions

- Zero/Tare
- Auto power off
- Display hold
- Unit switch
- Voltage display
- Resolution switch
- Overload warning

Weight and size 秤量和尺寸

Model	Max.cap. kg	d kg	n	A mm	B mm	C mm	L mm	N.W. kg
OCS-10 (Z)	10000	5	2000	105	140	70	850	60
OCS-15 (Z)	15000	5	3000	140	160	75	900	95
OCS-20 (Z)	20000	10	2000	150	180	80	950	95
OCS-30 (Z)	30000	10	3000	165	215	90	1120	165
OCS-50 (Z)	50000	20	2500	180	235	105	1350	295

➤ Any difference, subject to the actual dimension.

Specification 技术规范

Accuracy class	准确度等级	OIML Ⅲ
Tare range	去皮范围	100%F.S.
Zero range	置零范围	4%F.S.
Safe overload	安全载荷	120%F.S.
Ultimate overload	极限载荷	400%F.S.
Overload warning	超载警示值	100%F.S.+9e
Battery	电池	6V/10Ah
Adaptor	充电器	DC9V/1.5A
Battery life	连续工作时间	>60h
Temperature range	温度范围	-10℃~40℃

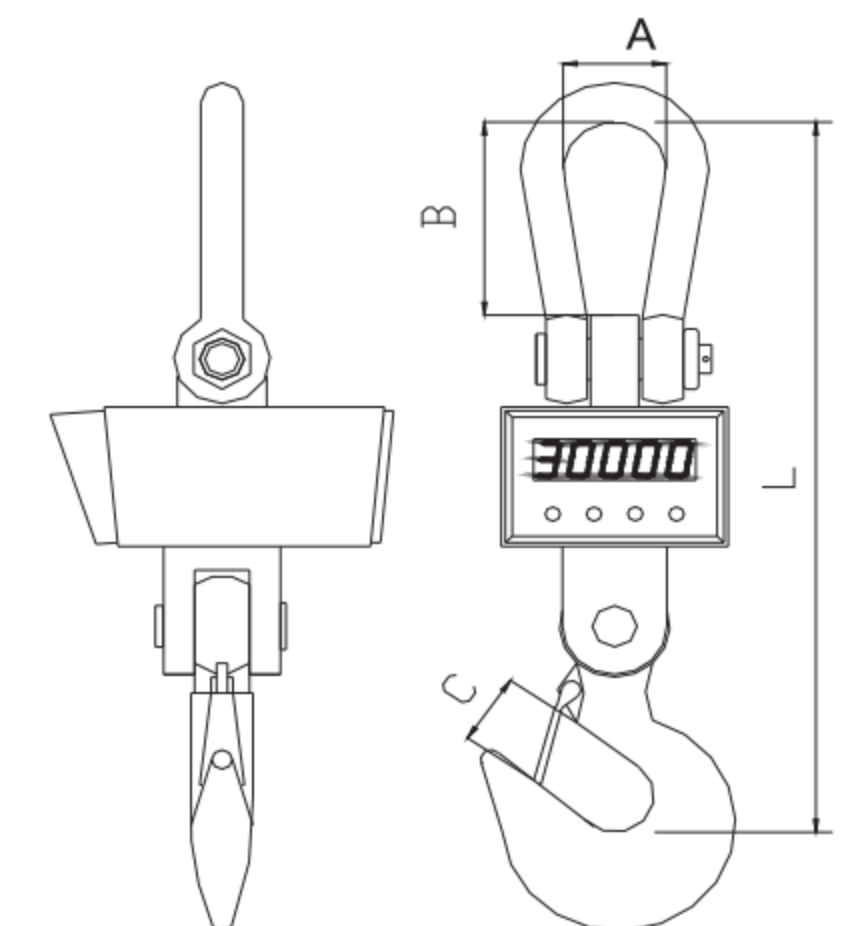

MODEL : OCS-XS (E1)

产品特点

- 全钢机壳
- 美标弓型吊环、环眼吊钩
- 优质合金钢传感器
- 更换式充电电池
- 称量数据无线电传输

显示仪表

- 精密模压合金铝机壳
- 工程塑料机箱
- 笔段式液晶显示屏
- 充电电池
- 微型点阵打印机
- 多种接口
- 尺寸：285*195*63mm

Features

- Alloy steel case
- Alloy steel load cell
- Alloy steel shackle and hook
- Rechargeable battery
- Wireless data transmission

Indicator features

- Aluminum alloy case
- ABS portable chassis
- LCD display
- Rechargeable battery
- Mini printer
- RS232 RS485
- Size: 285*195*63 mm

Functions

- Zero/Tare
- Tare weight set
- Time set
- Overload warning
- Voltage display
- Resolution switch
- Acc/Del/View

Weight and size 秤量和尺寸

Model	Max.cap. kg	d kg	n	A mm	B mm	C mm	L mm	N.W. kg
OCS-XS-1 (E1)	1000	0.5	2000	58	83	30	420	20
OCS-XS-3 (E1)	3000	1	3000	73	107	33	480	20
OCS-XS-5 (E1)	5000	2	2500	92	135	45	585	31
OCS-XS-10 (E1)	10000	5	2000	105	140	70	850	51
OCS-XS-15 (E1)	15000	5	3000	140	160	75	900	75
OCS-XS-20 (E1)	20000	10	2000	150	180	80	950	75
OCS-XS-30 (E1)	30000	10	3000	165	215	90	1120	170
OCS-XS-50 (E1)	50000	20	2500	180	235	105	1350	390

➤ Any difference, subject to the actual dimension.

Specification 技术规范

Accuracy class	准确度等级	OIML Ⅲ
Tare range	去皮范围	100%F.S.
Zero range	置零范围	4%F.S.
Safe overload	安全载荷	120%F.S.
Ultimate overload	极限载荷	400%F.S.
Overload warning	超载警示值	100%F.S.+9e
Battery	电池	6V/4Ah*2
Adaptor	充电器	DC9V/1.5A,DC7.2V/1A
Wireless frequency	无线电频率	450MHz
Wireless distance	通讯距离	>100m
Temperature range	温度范围	-10°C~40°C

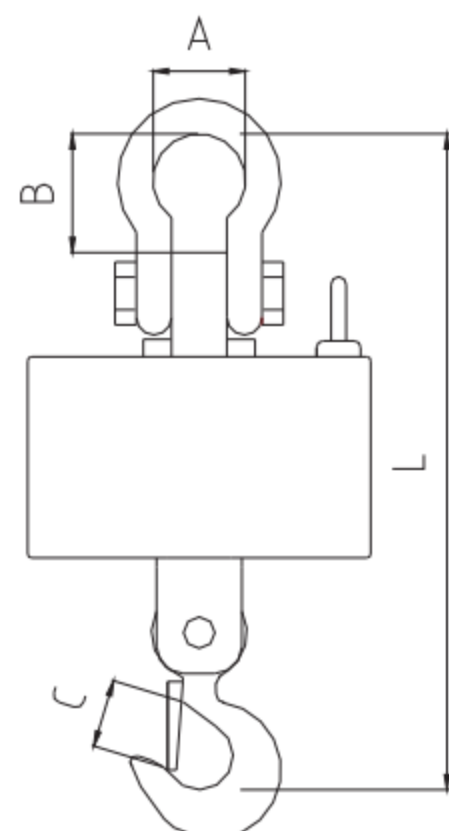

MODEL : OCS-XS (F2)

产品特点

- 精密铸钢机壳
- 工业级镀膜处理
- 美标弓型吊环、环眼吊钩
- 整体式载荷结构
- 更换式充电电池
- 称量数据无线电传输

显示仪表

- 精密模压合金铝机壳
- 工程塑料机箱
- 笔段式液晶显示屏
- 充电电池
- 微型点阵打印机
- 多种接口
- 尺寸：285*195*63mm

Features

- Alloy steel case
- High strength paint
- Alloy steel load cell
- Alloy steel rings and rotating hook
- Rechargeable battery
- Wireless data transmission

Indicator features

- Aluminum alloy case
- ABS portable chassis
- LCD display
- Rechargeable battery
- Mini printer
- RS232 RS485
- Size: 285*195*63 mm

Functions

- Zero/Tare
- Tare weight set
- Time set
- Overload warning
- Voltage display
- Resolution switch
- Acc/Del/View

Weight and size 秤量和尺寸

Model	Max.cap. kg	d kg	n	A mm	B mm	C mm	L mm	N.W. kg
OCS-XS-5 (F2)	5000	2	2500	105	140	70	850	25
OCS-XS-10 (F2)	10000	5	2000	105	140	70	850	45
OCS-XS-15 (F2)	15000	5	3000	140	160	75	900	75
OCS-XS-20 (F2)	20000	10	2000	150	180	80	950	75

➤ Any difference, subject to the actual dimension.

如有改进之处，仍以实物为主。

Specification 技术规范

Accuracy class	准确度等级	OIML Ⅲ
Tare range	去皮范围	100%F.S.
Zero range	置零范围	4%F.S.
Safe overload	安全载荷	120%F.S.
Ultimate overload	极限载荷	400%F.S.
Overload warning	超载警示值	100%F.S.+9e
Battery	电池	6V/4Ah*2
Adaptor	充电器	DC9V/1.5A,DC7.2V/1A
Wireless frequency	无线电频率	450MHz
Wireless distance	通讯距离	>100m
Temperature range	温度范围	-10°C~40°C

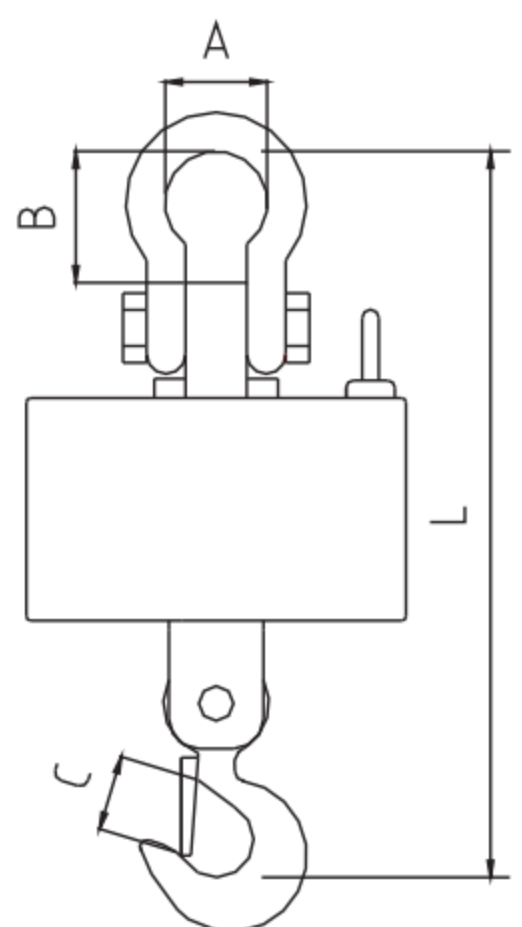

MODEL : OCS (G1)

产品特点

- 精密模压合金铝机壳
- 工业级镀膜处理
- 美标弓型吊环、环眼吊钩
- 高强度合金钢传感器
- 字高30mm LED 显示
- 大容量充电电池
- 红外遥控器

基本功能

- 置零去皮
- 自动关机
- 示值保持
- 单位切换
- 电压显示
- 分度切换
- 超载警示

Features

- Precision aluminum alloy case
- High strength paint
- Alloy steel load cell
- 30mm LED display
- Alloy steel shackle and hook
- Rechargeable battery
- Infrared remote control

Safe distance 最小安全距离

熔液温度 Temperature	安全距离 Safe distance	熔液温度 Temperature	安全距离 Safe distance
1000°C	1.2m	1400°C	1.8m
1200°C	1.5m	1600°C	2.0m

Weight and size 秤量和尺寸

Model	Max.cap. kg	d kg	n	A mm	B mm	C mm	L mm	N.W. kg
OCS-1 (G1)	1000	0.5	2000	92	100	55	730	28
OCS-2 (G1)	2000	1	2000	92	100	55	730	28
OCS-3 (G1)	3000	1	3000	92	100	55	730	28
OCS-5 (G1)	5000	2	2500	98	125	70	850	48
OCS-10 (G1)	10000	5	2000	130	140	70	900	64
OCS-15 (G1)	15000	5	3000	130	160	75	950	70

➤ Any difference, subject to the actual dimension.

Specification 技术规范

Accuracy class	准确度等级	OIML Ⅲ
Tare range	去皮范围	100%F.S.
Zero range	置零范围	4%F.S.
Safe overload	安全载荷	120%F.S.
Ultimate overload	极限载荷	500%F.S.
Overload warning	超载警示值	100%F.S.+9e
Battery	电池	6V/10Ah
Adaptor	充电器	DC9V/1.5A
Battery life	连续工作时间	>100h

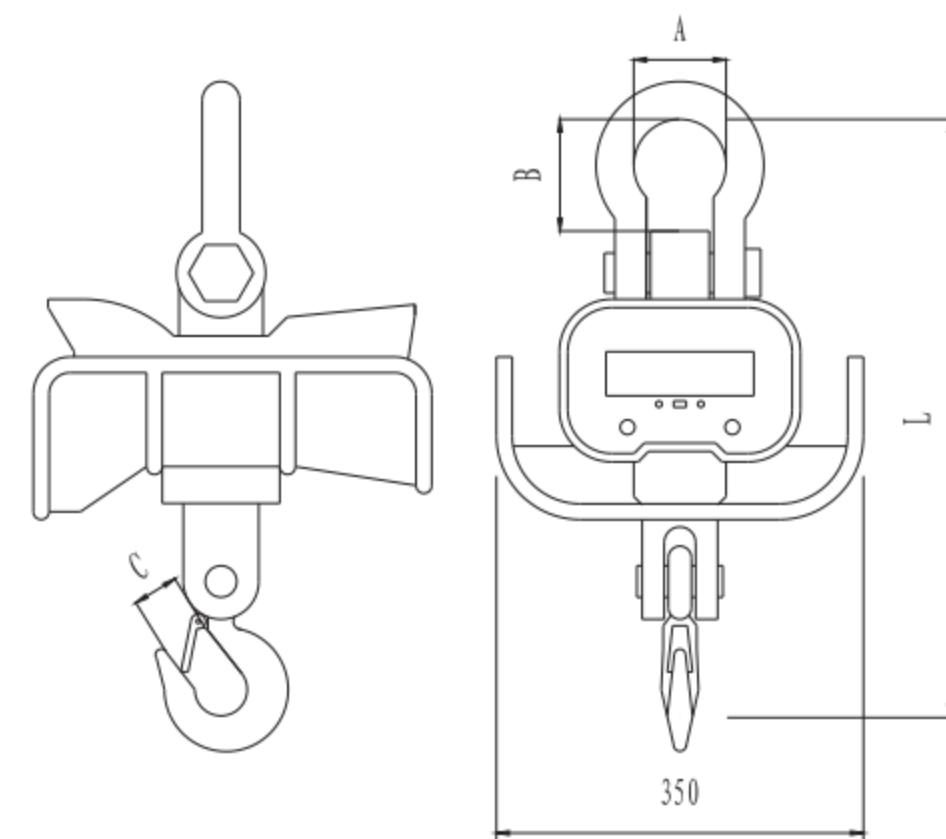

MODEL : OCS (G2)

产品特点

- 增强结构全钢机壳
- 工业级镀膜处理
- 合金钢弓型吊环、环眼吊钩
- 高强度合金钢传感器
- 字高56mm LED 显示
- 更换式充电电池
- 红外遥控器

基本功能

- 置零去皮
- 自动关机
- 示值保持
- 单位切换
- 电压显示
- 分度切换
- 超载警示

Features

- Alloy steel case
- High strength paint
- Alloy steel load cell
- 56mm LED display
- Alloy steel shackle and hook
- Infrared remote control

Safe distance 最小安全距离

熔液温度 Temperature	安全距离 Safe distance	熔液温度 Temperature	安全距离 Safe distance
1000°C	1.2m	1400°C	1.8m
1200°C	1.5m	1600°C	2.0m

Weight and size 秤量和尺寸

Model	Max.cap. kg	d kg	n	A mm	B mm	C mm	L mm	N.W. kg
OCS-5 (G2)	5000	2	2500	105	140	70	850	60
OCS-10 (G2)	10000	5	2000	140	160	75	900	80
OCS-15 (G2)	15000	5	3000	150	180	80	950	95
OCS-20 (G2)	20000	10	2000	165	215	90	1120	165
OCS-30 (G2)	30000	10	3000	180	235	105	1350	395

➤ Any difference, subject to the actual dimension.

Specification 技术规范

Accuracy class	准确度等级	OIML Ⅲ
Tare range	去皮范围	100%F.S.
Zero range	置零范围	4%F.S.
Safe overload	安全载荷	120%F.S.
Ultimate overload	极限载荷	500%F.S.
Overload warning	超载警示值	100%F.S.+9e
Battery	电池	6V/10Ah
Adaptor	充电器	DC9V/1.5A
Battery life	连续工作时间	>100h

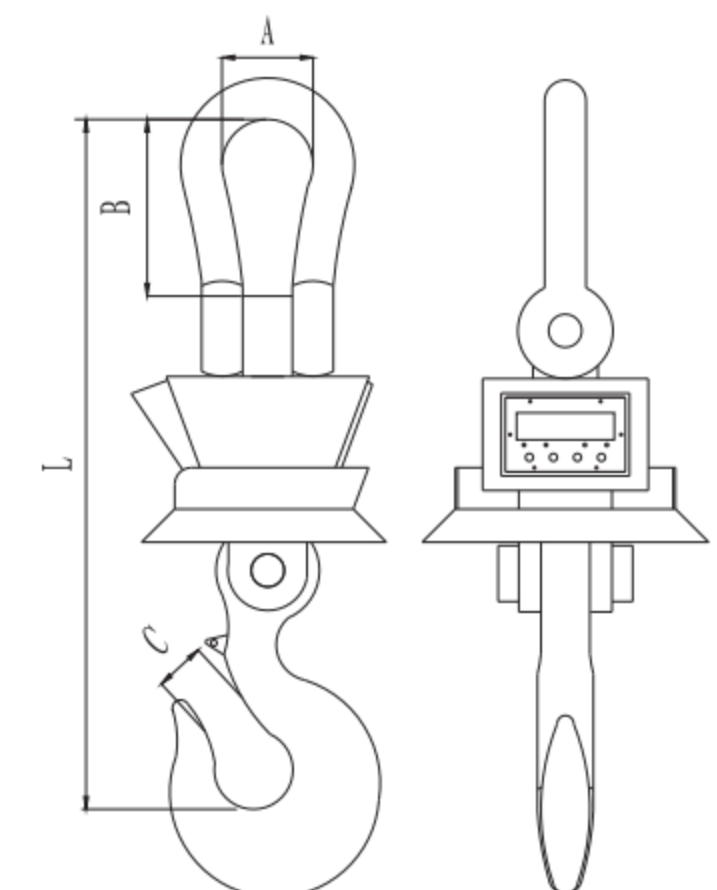

MODEL : OCS-XS (G)

无线耐热型

产品特点

- 全钢机壳
- 美标弓型吊环、环眼吊钩
- 优质合金钢传感器
- 更换式充电电池
- 称量数据无线电传输

显示仪表

- 精密模压合金铝机壳
- 工程塑料机箱
- 笔段式液晶显示屏
- 充电电池
- 微型点阵打印机
- 多种接口
- 尺寸：285*195*63mm

Features

- Alloy steel case
- Alloy steel load cell
- Alloy steel shackle and hook
- Rechargeable battery
- Wireless data transmission

Functions

- Zero/Tare
- Display hold
- Voltage display
- Overload warning
- Auto power off
- Unit switch
- Resolution switch

Safe distance 最小安全距离

熔液温度 Temperature	安全距离 Safe distance	熔液温度 Temperature	安全距离 Safe distance
1000°C	1.2m	1400°C	1.8m
1200°C	1.5m	1600°C	2.0m

Weight and size 秤量和尺寸

Model	Max.cap. kg	d kg	n	A mm	B mm	C mm	L mm	N.W. kg
OCS-XS-1 (G)	1000	0.5	2000	98	120	70	850	58
OCS-XS-3 (G)	3000	1	3000	98	120	70	850	58
OCS-XS-5 (G)	5000	2	2500	98	120	70	850	58
OCS-XS-10 (G)	10000	5	2000	130	140	80	900	88
OCS-XS-15 (G)	15000	5	3000	150	160	80	950	92
OCS-XS-20 (G)	20000	10	2000	165	180	90	1120	175
OCS-XS-30 (G)	30000	10	3000	220	380	105	1350	450

➤ Any difference, subject to the actual dimension.

Specification 技术规范

Accuracy class	准确度等级	OIML Ⅲ
Tare range	去皮范围	100%F.S.
Zero range	置零范围	4%F.S.
Safe overload	安全载荷	120%F.S.
Ultimate overload	极限载荷	500%F.S.
Overload warning	超载警示值	100%F.S.+9e
Battery	电池	6V/4Ah*2
Adaptor	充电器	DC9V/1.5A,DC7.2V/1A
Wireless frequency	无线电频率	450MHz
Wireless distance	通讯距离	>100m

